

# ***CCD Black-and-White Video Camera Module***

---

## **Technical Manual**



**XC-ES50/50CE  
XC-ES30/30CE  
XC-ES51/51CE  
XC-EI50/50CE  
XC-EI30/30CE**

# Table of Contents

## Overview 3

<b>Main Features</b> .....	<b>3</b>
<b>System Components</b> .....	<b>4</b>
<b>Connection Diagram</b> .....	<b>5</b>
<b>Location of Parts and Operation</b> .....	<b>6</b>
Front/Top/Bottom .....	6
Rear Panel .....	7

## Mode Setting 9

<b>Specifications of the Input/Output</b> .....	<b>9</b>
Input Phase Specifications of the External HD/VD .....	9
Specifications of the WEN Output .....	9
Specifications of the Trigger Pulse .....	9
<b>Normal Shutter</b> .....	<b>10</b>
Setting of the Normal Shutter .....	10
<b>External Trigger Shutter</b> .....	<b>10</b>
Setting of the External Trigger Shutter .....	10
<b>Restart/Reset</b> .....	<b>12</b>
To set Restart/Reset mode .....	12
<b>Timing Charts</b> .....	<b>14</b>
When set to Mode 1 .....	14
When set to Mode 2 .....	20

## Appendix 22

<b>Specifications</b> .....	<b>22</b>
<b>Dimensions</b> .....	<b>25</b>
XC-ES50/50CE/ES30/30CE/ES51/51CE/ EI50/50CE/EI30/30CE .....	25
<b>Spectral Sensitivity Characteristics (Lens characteristics included, and light source characteristics excluded)</b> .....	<b>26</b>
XC-ES30 .....	26
XC-ES30CE .....	26
XC-ES50/ES51 .....	26
XC-ES50CE/ES51CE .....	26
XC-EI30 .....	27
XC-ES30CE .....	27
XC-EI50 .....	27
XC-EI50CE .....	27
<b>CCD Output Waveform Timing Chart</b> .....	<b>28</b>
XC-ES50/ES51/EI50/ES30/EI30 .....	28
XC-ES50CE/ES51CE/EI50CE/ES30CE/EI30CE .....	30

# Overview

The XC-ES50/50CE, XC-ES51/51CE, XC-EI50/50CE (with a 1/2 type CCD) and XC-ES30/30CE, XC-EI30/30CE (with a 1/3 type CCD) are industrial black-and-white video camera modules. The 1/2- and 1/3-inch C-mount commonly used in industrial applications implement compact size and light weight. The mode switches on the rear panel, which have been inherited from the XC-ST series, provide improved operability. The XC-EI series uses a CCD that has near-infrared sensitivity, which allows you to capture clear images even in low-intensity illumination. Like the existing models, they provide high vibration resistance to support installation on FA equipment.

---

## Main Features

---

### Various mode settings

Rear panel switches allow the following mode settings.

- Gain: Auto/Manual
- $\gamma$  compensation
- Synchronized input/output
- Potential accumulation: FRAME/FIELD
- 75  $\Omega$  termination
- Shutter: Normal/Trigger shutter

---

### External synchronization

The camera module automatically determines whether to operate in interlace or non-interlace mode from the HD (horizontal drive) and VD (vertical drive) signals input for external synchronization.

---

### Internal sync signal output

You can output the HD and VD signals from the 12-pin connector by changing the setting of the rear panel switch.

---

### External trigger shutter function (EIA: 1/4 to 1/10,000 seconds, CCIR: 1/4 to 1/8,000 seconds)

You can obtain a freeze picture by inputting an external trigger. This function is useful for shooting a fast-moving object clearly.

---

### Restart/Reset function

Inputting external HD and VD signals (2 VD or more) continuously can catch one image at an arbitrary point in time and control the stored CCD.

This function is used for long exposures and with strobe for frame image output.

---

### Body fixing

Mounting screw holes are provided in the reference plane on the lower surface of the body. They allow you to install the camera module with a minimum deviation of the optical axis.

---

### The connector complies with the new EIAJ 12-pin pin assignment

The new pin arrangement allows the connector to accept a trigger pulse and a WEN signal.

# System Components

The XC-E series Video Camera Module system comprises the following components.

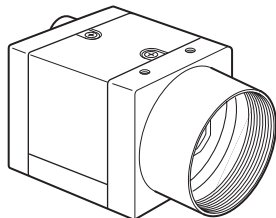

Video camera module  
XC-ES50/50CE  
XC-ES30/30CE  
XC-ES51/51CE  
XC-EI50/50CE  
XC-EI30/30CE

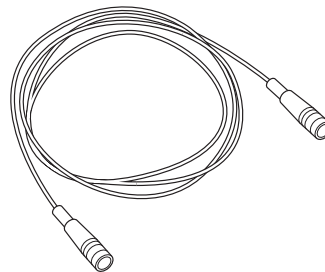

Camera cables  
CCXC-12P02N(2 m)  
CCXC-12P05N(5 m)  
CCXC-12P10N(10 m)  
CCXC-12P25N(25 m)

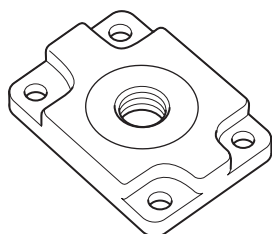

Tripod adaptor  
VCT-333I  
(Insulated type)

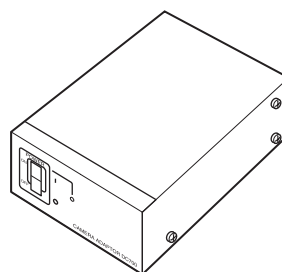

Camera adaptor  
DC-700/700CE

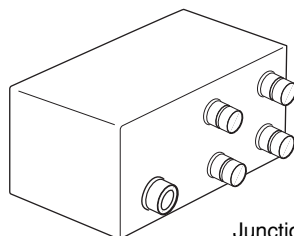

Junction box  
JB-77

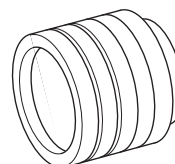

C-mount lens  
VCL-50Y-M  
VCL-25Y-M  
VCL-16Y-M  
VCL-12YM  
VCL-08YM

# Connection Diagram

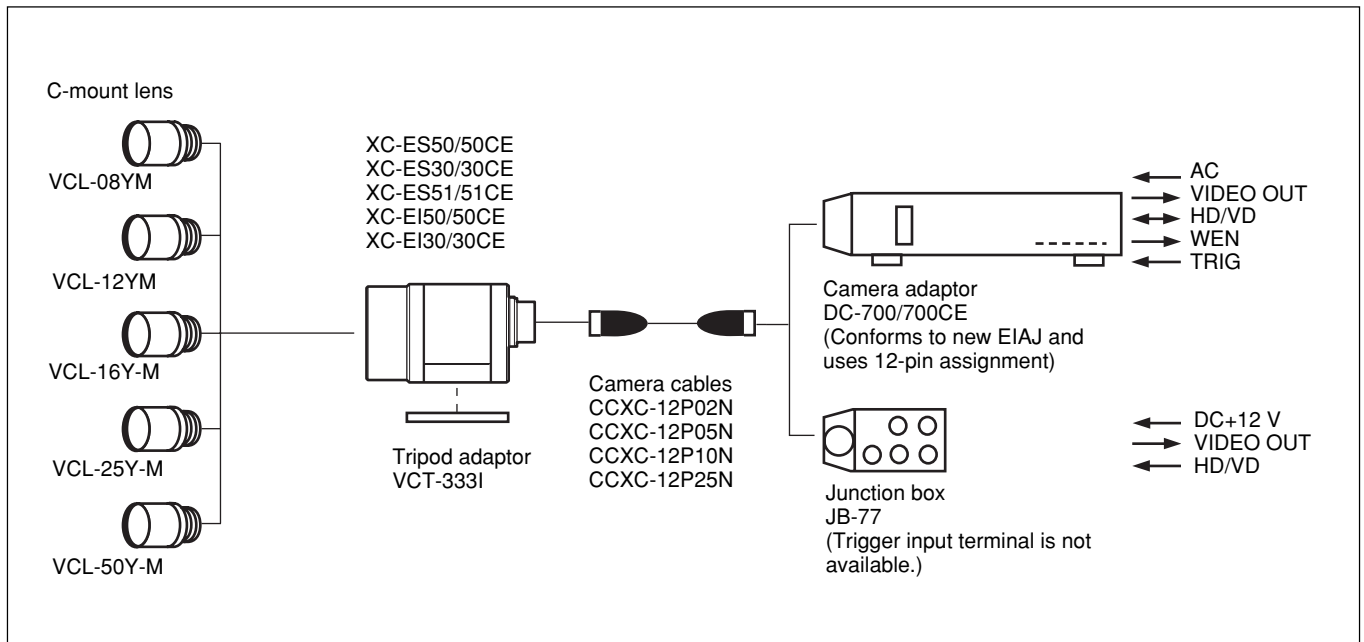

**Note**

When using with the JB-77, some functions of the XC-ES50/50CE, XC-ES51/51CE, XC-EI50/50CE, XC-ES30/30CE and XC-EI30/30CE are not available. Refer to the table on the right.

XC-ES50/50CE XC-ES51/51CE XC-EI50/50CE XC-ES30/30CE XC-EI30/30CE	JB-77
Normal	○
Normal shutter	○
Rester Reset (R.R)	○
Rester Reset (R.R) + Shutter	○
External trigger shutter	×

○: Available  
×: Not available

# Location of Parts and Operation

## Front/Top/Bottom

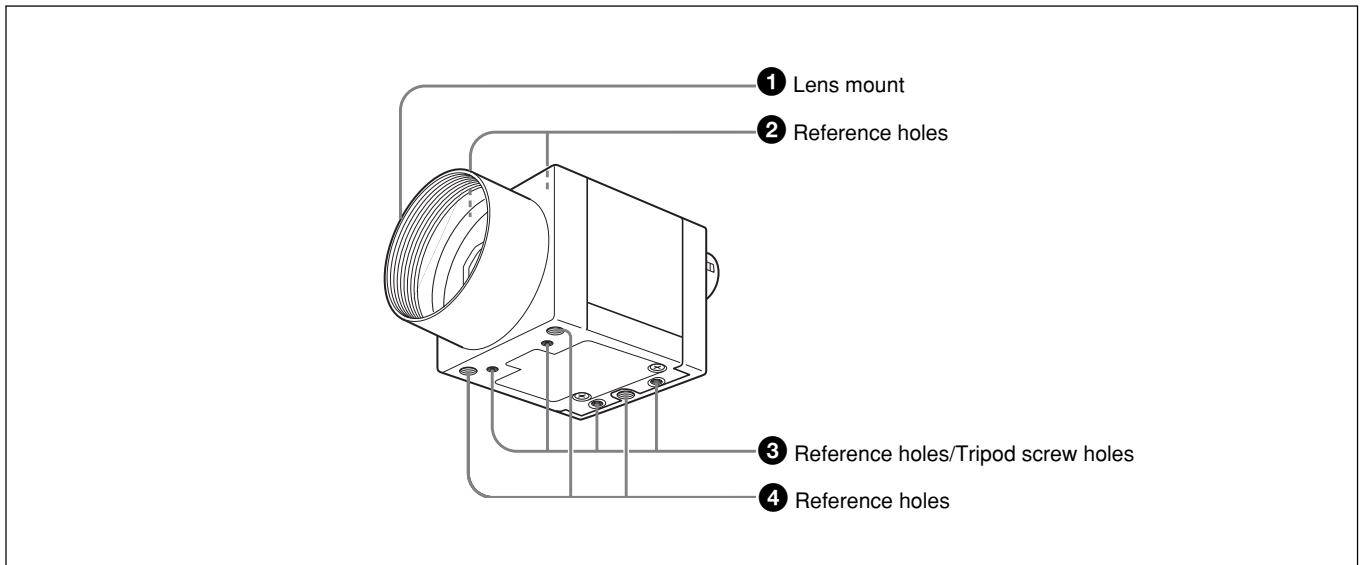

### ❶ Lens mount (C-mount)

Attach the C-mount lens or other optical equipment.

#### Note

The lens must not project more than 7 mm (9/32 inch) from the lens mount.

### ❷ Reference holes (Top)

These precision screw holes are for locking the camera module. They allow you to install the camera module with a minimum deviation of the optical axis.

### ❸ Reference holes/Tripod screw holes (Bottom)

These precision screw holes are for locking the camera module. They allow you to install the camera module with a minimum deviation of the optical axis.

They also can be used for mounting the camera module on a tripod. Attach the VCT-333I tripod adaptor to the camera module using these screws.

### ❹ Reference holes (Bottom)

These precision screw holes are for locking the camera module. They allow you to install the camera module with a minimum deviation of the optical axis.

## Rear Panel

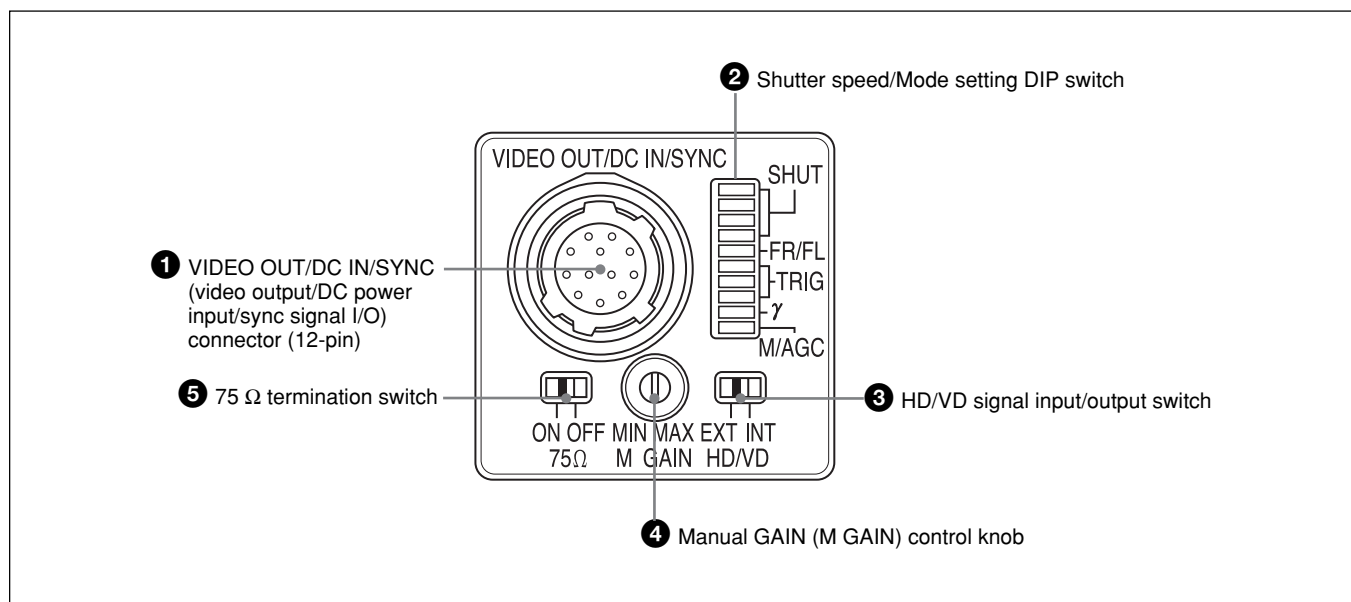

### Note

Be sure to turn off the power before making switch settings.

### 1 VIDEO OUT/DC IN/SYNC (video output/DC power input/sync signal I/O) connector (12-pin)

Connect the CCXC-12P05N camera cable to this connector to receive the +12 V DC power supply and output the video signal. When a sync signal generator is connected to this connector, the camera module is synchronized with the external sync signals (HD/VD signals).

### 2 Shutter speed/Mode setting DIP switch

#### Shutter speed (bits 1–4):

Set an appropriate shutter speed. (Factory setting: OFF)

#### Potential accumulation mode (bit 5):

(Factory setting: FRAME)

#### Restart reset/External trigger shutter mode switch (bits 6–8):

(Factory setting: Normal)

#### γ compensation ON/OFF switch (bit 9):

Turn on the switch to enable the γ compensation. (Factory setting: OFF)

#### GAIN switch (bit 0):

This switch selects MGC (manual adjustment) or AGC (automatic adjustment). (Factory setting: MGC)

### 3 HD/VD signal input/output switch

Set the switch to INT to output HD/VD signals from the camera module.

Set the switch to EXT to input HD/VD signals from an external unit. (Factory setting: EXT)

### 4 Manual GAIN (M GAIN) control knob

If you have selected MGC with the GAIN switch (DIP switch 2), this knob adjusts the gain. (Factory setting: twelve o'clock position)

### Note

If you have selected FRAME using the Potential accumulation mode (DIP switch 2), set this knob to MAX. (This is due to requirement CCD.)

### 5 75 Ω termination switch

Turn it to OFF when not terminating. (Factory setting: ON)

### Note

The rear panel shown above is for the models with the following serial numbers.

XC-ES50/EI50/ES30/EI30: 200001 or later.

XC-ES51: 100001 or later.

XC-ES50CE/EI50CE/ES30CE/EI30CE: 500001 or later.

XC-ES51CE: 400001 or later.

## VIDEO OUT/DC IN/SYNC connector pin assignment

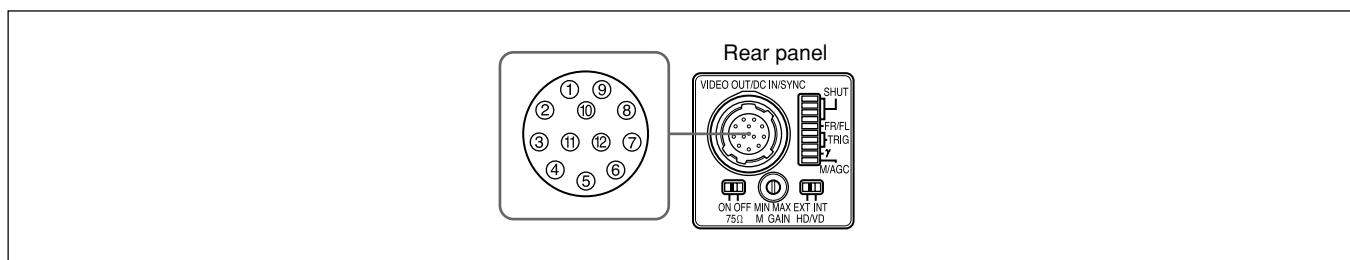

Pin No.	Camera sync output	External Sync (HD/VD)	Restart/Reset	External trigger shutter
1	Ground	Ground	Ground	Ground
2	+12 V DC	+12 V DC	+12 V DC	+12 V DC
3	Video output (Ground)	Video output (Ground)	Video output (Ground)	Video output (Ground)
4	Video output (Signal)	Video output (Signal)	Video output (Signal)	Video output (Signal)
5	HD output (Ground)	HD input (Ground)	HD input (Ground)	HD input (Ground)
6	HD output (Signal)	HD input (Signal)	HD input (Signal)	HD input (Signal)
7	VD output (Signal)	VD input (Signal)	Reset (Signal)	VD input (Signal)
8	—	—	—	—
9	—	—	—	—
10	—	—	—	WEN output (Signal)
11	—	—	—	Trigger pulse input (Signal)
12	VD output (Ground)	VD input (Ground)	Reset (Ground)	VD input (Ground)

## Factory setting mode of rear panel

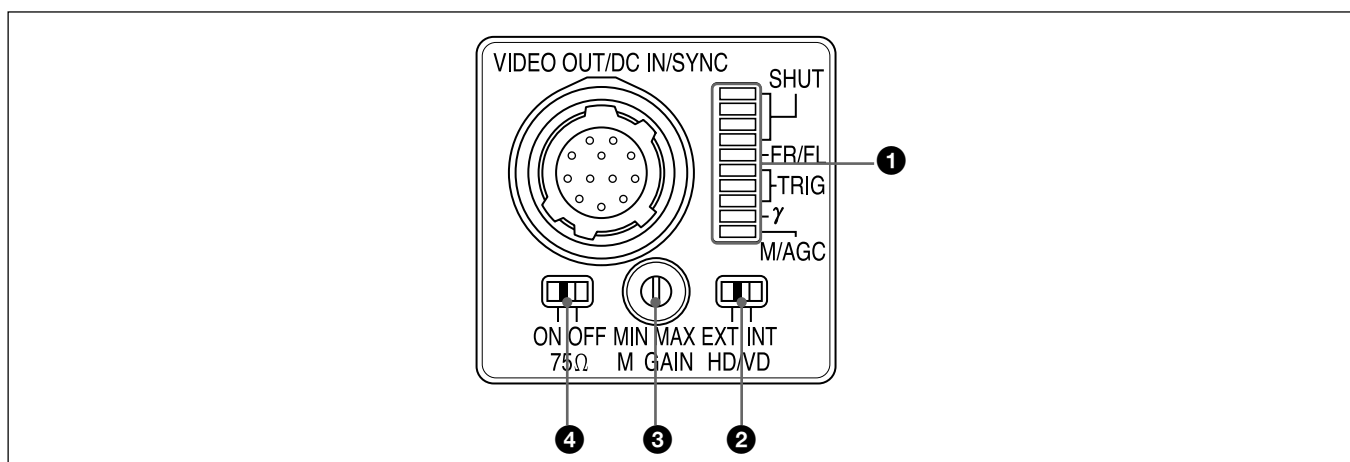

Number	Switch name	Factory-setting mode
①	Shutter speed (bits 1–4)	OFF
	Potential accumulation mode (bit 5)	FRAME
	Restart reset/External trigger shutter mode switch (bits 6–8)	Normal
	γ compensation ON/OFF switch (bit 9)	OFF
	GAIN switch (bit 0)	MGC
②	HD/VD signal input/output switch	EXT
③	Manual GAIN (M GAIN) control knob	twelve o'clock position*
④	75 Ω termination switch	ON

\* When the GAIN switch is set to "MGC" (Manual), you can change the gain level in a range from 0 to 18 dB.

# Mode Setting

## Specifications of the Input/Output

### Input Phase Specifications of the External HD/VD

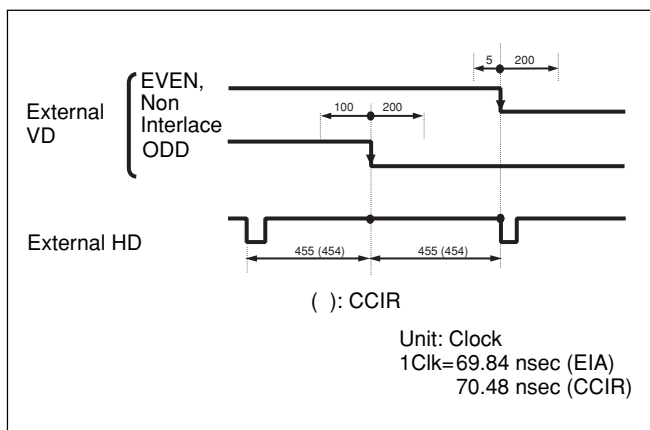

Make sure that the external HD/VD phases against the standard central phase are as shown in the figure above. Invalid signal input may cause an error in the internal reset.

When you restart/reset the camera or operate the camera by inputting an external trigger shutter pulse, the Vsync signal for the image is output 1 H later from the external VD.

#### Normal:

HD/VD continuous (EIA/CCIR frequencies: Maintained. Timing: See the figure above.)

#### Restart/Reset or External trigger shutter

HD continuous/VD (Reset): Any timing if the phase with HD is within the above range.

### Specifications of the WEN Output

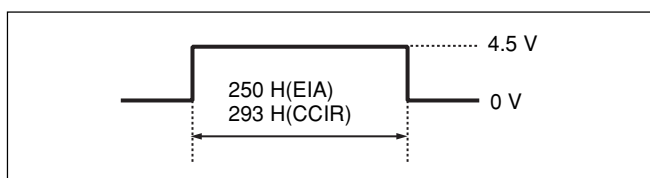

The amplitude level is the typical value when terminated with 10 kΩ.

### Specifications of the Trigger Pulse

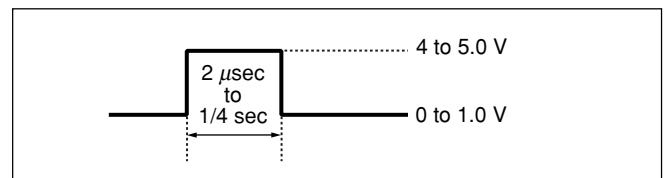

- Input impedance: 10 kΩ or more.
- The voltage and pulse width used are measured at pin 11 of a 12-pin multi-connector on the rear panel.
- If you set the trigger pulse with the DIP switches, use the 100 μs to 1/4 sec pulse width.

#### Setting the external shutter speed with the trigger pulse width

Set the DIP switches 1 to 4 to 0.

You can obtain an arbitrary shutter speed by setting the trigger pulse width to the range of 2 μsec to 250 msec.

Mode 1 (Non-reset mode)

Mode 2 (Reset mode)



Exposure time = Trigger pulse width + 97 μsec (EIA)  
Trigger pulse width + 120 μsec (CCIR)

#### Notes

- The DIP switch 5 position is optional. (The field setting is recommended.) The field setting can obtain a sensitivity that is twice that of the frame setting.
- An image will not be output correctly if another trigger is input before the image for the previous trigger is output.

# Normal Shutter

This mode provides continuous video output with the electronic shutter selected by switches to capture a high-speed moving object clearly.

## Setting of the Normal Shutter

Using the DIP switches on the rear panel

Shutter OFF	1/125	1/250	1/500	1/1000
1 <input type="checkbox"/>	1 <input type="checkbox"/>	1 <input type="checkbox"/>	1 <input type="checkbox"/>	1 <input type="checkbox"/>
2 <input type="checkbox"/>	2 <input type="checkbox"/>	2 <input type="checkbox"/>	2 <input type="checkbox"/>	2 <input type="checkbox"/>
3 <input type="checkbox"/>	3 <input type="checkbox"/>	3 <input type="checkbox"/>	3 <input type="checkbox"/>	3 <input type="checkbox"/>
4 <input type="checkbox"/>	4 <input type="checkbox"/>	4 <input type="checkbox"/>	4 <input type="checkbox"/>	4 <input type="checkbox"/>
5 <input type="checkbox"/>	5 <input type="checkbox"/>	5 <input type="checkbox"/>	5 <input type="checkbox"/>	5 <input type="checkbox"/>
6 <input type="checkbox"/>	6 <input type="checkbox"/>	6 <input type="checkbox"/>	6 <input type="checkbox"/>	6 <input type="checkbox"/>
7 <input type="checkbox"/>	7 <input type="checkbox"/>	7 <input type="checkbox"/>	7 <input type="checkbox"/>	7 <input type="checkbox"/>
8 <input type="checkbox"/>	8 <input type="checkbox"/>	8 <input type="checkbox"/>	8 <input type="checkbox"/>	8 <input type="checkbox"/>
9 <input type="checkbox"/>	9 <input type="checkbox"/>	9 <input type="checkbox"/>	9 <input type="checkbox"/>	9 <input type="checkbox"/>
0 <input type="checkbox"/>	0 <input type="checkbox"/>	0 <input type="checkbox"/>	0 <input type="checkbox"/>	0 <input type="checkbox"/>
1/2000	1/4000	1/10000 (EIA) 1/8000 (CCIR)	Flickerless* (EIA: 1/100 CCIR: 1/120)	
1 <input type="checkbox"/>	1 <input type="checkbox"/>	1 <input type="checkbox"/>	1 <input type="checkbox"/>	
2 <input type="checkbox"/>	2 <input type="checkbox"/>	2 <input type="checkbox"/>	2 <input type="checkbox"/>	
3 <input type="checkbox"/>	3 <input type="checkbox"/>	3 <input type="checkbox"/>	3 <input type="checkbox"/>	
4 <input type="checkbox"/>	4 <input type="checkbox"/>	4 <input type="checkbox"/>	4 <input type="checkbox"/>	
5 <input type="checkbox"/>	5 <input type="checkbox"/>	5 <input type="checkbox"/>	5 <input type="checkbox"/>	
6 <input type="checkbox"/>	6 <input type="checkbox"/>	6 <input type="checkbox"/>	6 <input type="checkbox"/>	
7 <input type="checkbox"/>	7 <input type="checkbox"/>	7 <input type="checkbox"/>	7 <input type="checkbox"/>	
8 <input type="checkbox"/>	8 <input type="checkbox"/>	8 <input type="checkbox"/>	8 <input type="checkbox"/>	
9 <input type="checkbox"/>	9 <input type="checkbox"/>	9 <input type="checkbox"/>	9 <input type="checkbox"/>	
0 <input type="checkbox"/>	0 <input type="checkbox"/>	0 <input type="checkbox"/>	0 <input type="checkbox"/>	

(Unit: second)

\* If you set the mode to flickerless, the positions of DIP switches 1 to 3 are optional.

### Notes

- The positions of DIP switches 6 and 7 are optional.
- The DIP switch 5 position is optional. (The field setting is recommended.) The field setting can obtain a sensitivity that is twice that of the frame setting.

# External Trigger Shutter

By inputting an external trigger pulse, the camera is able to capture fast-moving objects clearly.

Set DIP switches 6, 7, and 8 on the rear panel to Mode 1 or Mode 2 (See the table below).

When you set the trigger pulse width to 1/3 of a second or more, the output signal changes to the normal VIDEO signal.

There are two modes for timing in which a video signal is obtained.

### • Mode 1 (Non-reset mode)

In this mode, a video signal synchronized with a VD signal is output after a trigger pulse is input.

- A video signal is synchronized with the external VD signal when an external HD/VD signal is input.
- A video signal is synchronized with an internal VD signal when no external HD/VD signal is input.

### • Mode 2 (Reset mode)

In this mode, an internal VD is reset, then an internal video signal is output after trigger pulse input after a certain period of time.

For details of each timing chart, see pages 14 to 21.

## Setting of the External Trigger Shutter

You can set the shutter speed with the DIP switches or using the trigger pulse width.

To set the shutter speed with the trigger pulse width, see page 9.

Using the DIP switches on the rear panel

Mode 1 (Non-reset mode)

1/100 (EIA)* 1/120 (CCIR)*	1/125	1/250	1/500
1 <input type="checkbox"/>	1 <input type="checkbox"/>	1 <input type="checkbox"/>	1 <input type="checkbox"/>
2 <input type="checkbox"/>	2 <input type="checkbox"/>	2 <input type="checkbox"/>	2 <input type="checkbox"/>
3 <input type="checkbox"/>	3 <input type="checkbox"/>	3 <input type="checkbox"/>	3 <input type="checkbox"/>
4 <input type="checkbox"/>	4 <input type="checkbox"/>	4 <input type="checkbox"/>	4 <input type="checkbox"/>
5 <input type="checkbox"/>	5 <input type="checkbox"/>	5 <input type="checkbox"/>	5 <input type="checkbox"/>
6 <input type="checkbox"/>	6 <input type="checkbox"/>	6 <input type="checkbox"/>	6 <input type="checkbox"/>
7 <input type="checkbox"/>	7 <input type="checkbox"/>	7 <input type="checkbox"/>	7 <input type="checkbox"/>
8 <input type="checkbox"/>	8 <input type="checkbox"/>	8 <input type="checkbox"/>	8 <input type="checkbox"/>
9 <input type="checkbox"/>	9 <input type="checkbox"/>	9 <input type="checkbox"/>	9 <input type="checkbox"/>
0 <input type="checkbox"/>	0 <input type="checkbox"/>	0 <input type="checkbox"/>	0 <input type="checkbox"/>
1/1000	1/2000	1/4000	1/10000 (EIA) 1/8000 (CCIR)
1 <input type="checkbox"/>	1 <input type="checkbox"/>	1 <input type="checkbox"/>	1 <input type="checkbox"/>
2 <input type="checkbox"/>	2 <input type="checkbox"/>	2 <input type="checkbox"/>	2 <input type="checkbox"/>
3 <input type="checkbox"/>	3 <input type="checkbox"/>	3 <input type="checkbox"/>	3 <input type="checkbox"/>
4 <input type="checkbox"/>	4 <input type="checkbox"/>	4 <input type="checkbox"/>	4 <input type="checkbox"/>
5 <input type="checkbox"/>	5 <input type="checkbox"/>	5 <input type="checkbox"/>	5 <input type="checkbox"/>
6 <input type="checkbox"/>	6 <input type="checkbox"/>	6 <input type="checkbox"/>	6 <input type="checkbox"/>
7 <input type="checkbox"/>	7 <input type="checkbox"/>	7 <input type="checkbox"/>	7 <input type="checkbox"/>
8 <input type="checkbox"/>	8 <input type="checkbox"/>	8 <input type="checkbox"/>	8 <input type="checkbox"/>
9 <input type="checkbox"/>	9 <input type="checkbox"/>	9 <input type="checkbox"/>	9 <input type="checkbox"/>
0 <input type="checkbox"/>	0 <input type="checkbox"/>	0 <input type="checkbox"/>	0 <input type="checkbox"/>

(Unit: second)

Mode 2 (Reset mode)

1/100 (EIA)* 1/120 (CCIR)*	1/125	1/250	1/500
1 <input type="checkbox"/> <input type="checkbox"/>	1 <input type="checkbox"/> <input type="checkbox"/>	1 <input type="checkbox"/> <input type="checkbox"/>	1 <input type="checkbox"/> <input type="checkbox"/>
2 <input type="checkbox"/> <input type="checkbox"/>	2 <input type="checkbox"/> <input type="checkbox"/>	2 <input type="checkbox"/> <input type="checkbox"/>	2 <input type="checkbox"/> <input type="checkbox"/>
3 <input type="checkbox"/> <input type="checkbox"/>	3 <input type="checkbox"/> <input type="checkbox"/>	3 <input type="checkbox"/> <input type="checkbox"/>	3 <input type="checkbox"/> <input type="checkbox"/>
4 <input type="checkbox"/> <input type="checkbox"/>	4 <input type="checkbox"/> <input type="checkbox"/>	4 <input type="checkbox"/> <input type="checkbox"/>	4 <input type="checkbox"/> <input type="checkbox"/>
5 <input type="checkbox"/> <input type="checkbox"/>	5 <input type="checkbox"/> <input type="checkbox"/>	5 <input type="checkbox"/> <input type="checkbox"/>	5 <input type="checkbox"/> <input type="checkbox"/>
6 <input type="checkbox"/> <input type="checkbox"/>	6 <input type="checkbox"/> <input type="checkbox"/>	6 <input type="checkbox"/> <input type="checkbox"/>	6 <input type="checkbox"/> <input type="checkbox"/>
7 <input type="checkbox"/> <input type="checkbox"/>	7 <input type="checkbox"/> <input type="checkbox"/>	7 <input type="checkbox"/> <input type="checkbox"/>	7 <input type="checkbox"/> <input type="checkbox"/>
8 <input type="checkbox"/> <input type="checkbox"/>	8 <input type="checkbox"/> <input type="checkbox"/>	8 <input type="checkbox"/> <input type="checkbox"/>	8 <input type="checkbox"/> <input type="checkbox"/>
9 <input type="checkbox"/> <input type="checkbox"/>	9 <input type="checkbox"/> <input type="checkbox"/>	9 <input type="checkbox"/> <input type="checkbox"/>	9 <input type="checkbox"/> <input type="checkbox"/>
0 <input type="checkbox"/> <input type="checkbox"/>	0 <input type="checkbox"/> <input type="checkbox"/>	0 <input type="checkbox"/> <input type="checkbox"/>	0 <input type="checkbox"/> <input type="checkbox"/>
1/1000	1/2000	1/4000	1/10000 (EIA) 1/8000 (CCIR)
1 <input type="checkbox"/> <input type="checkbox"/>	1 <input type="checkbox"/> <input type="checkbox"/>	1 <input type="checkbox"/> <input type="checkbox"/>	1 <input type="checkbox"/> <input type="checkbox"/>
2 <input type="checkbox"/> <input type="checkbox"/>	2 <input type="checkbox"/> <input type="checkbox"/>	2 <input type="checkbox"/> <input type="checkbox"/>	2 <input type="checkbox"/> <input type="checkbox"/>
3 <input type="checkbox"/> <input type="checkbox"/>	3 <input type="checkbox"/> <input type="checkbox"/>	3 <input type="checkbox"/> <input type="checkbox"/>	3 <input type="checkbox"/> <input type="checkbox"/>
4 <input type="checkbox"/> <input type="checkbox"/>	4 <input type="checkbox"/> <input type="checkbox"/>	4 <input type="checkbox"/> <input type="checkbox"/>	4 <input type="checkbox"/> <input type="checkbox"/>
5 <input type="checkbox"/> <input type="checkbox"/>	5 <input type="checkbox"/> <input type="checkbox"/>	5 <input type="checkbox"/> <input type="checkbox"/>	5 <input type="checkbox"/> <input type="checkbox"/>
6 <input type="checkbox"/> <input type="checkbox"/>	6 <input type="checkbox"/> <input type="checkbox"/>	6 <input type="checkbox"/> <input type="checkbox"/>	6 <input type="checkbox"/> <input type="checkbox"/>
7 <input type="checkbox"/> <input type="checkbox"/>	7 <input type="checkbox"/> <input type="checkbox"/>	7 <input type="checkbox"/> <input type="checkbox"/>	7 <input type="checkbox"/> <input type="checkbox"/>
8 <input type="checkbox"/> <input type="checkbox"/>	8 <input type="checkbox"/> <input type="checkbox"/>	8 <input type="checkbox"/> <input type="checkbox"/>	8 <input type="checkbox"/> <input type="checkbox"/>
9 <input type="checkbox"/> <input type="checkbox"/>	9 <input type="checkbox"/> <input type="checkbox"/>	9 <input type="checkbox"/> <input type="checkbox"/>	9 <input type="checkbox"/> <input type="checkbox"/>
0 <input type="checkbox"/> <input type="checkbox"/>	0 <input type="checkbox"/> <input type="checkbox"/>	0 <input type="checkbox"/> <input type="checkbox"/>	0 <input type="checkbox"/> <input type="checkbox"/>

(Unit: second)

\* If 1/100 (EIA) or 1/120 (CCIR) has been set, the positions of DIP switches 1 to 3 are optional.

**Note**

The positions of DIP switches 5, 9 and 0 are optional.

# Restart/Reset

## To set Restart/Reset mode

The information on one screen can be extracted at any time by externally inputting a restart/reset signal (HD/VD). To enter this mode, set DIP switches 6, 7, and 8 on the rear panel of the camera as shown in the figure below. The setting is especially effective for the operation explained below.

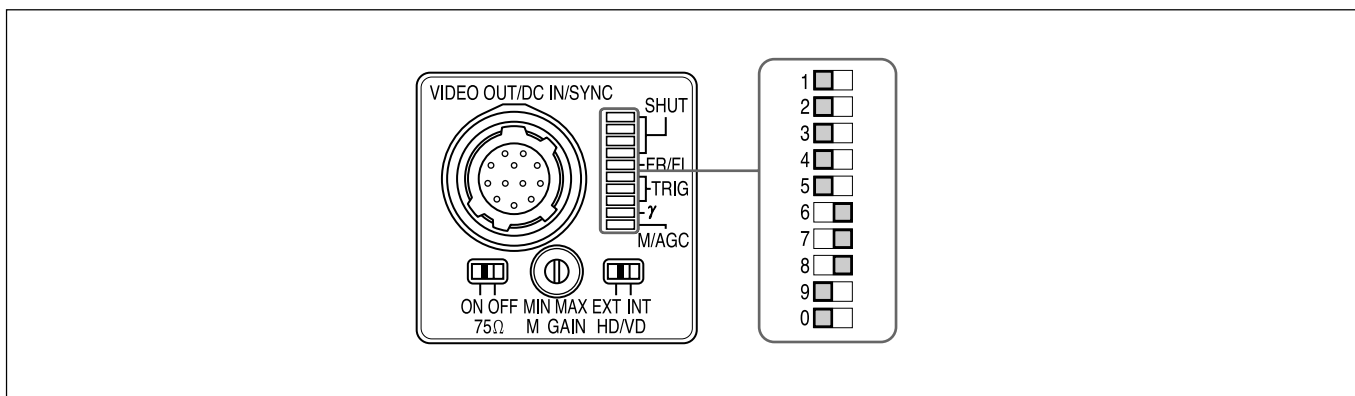

## Long exposure

The Restart/Reset function extends the CCD accumulation time, resulting in a highly sensitive image. This function is effective when you cannot gain satisfactory sensitivity under normal operating conditions, or when you want to observe a moving object. Extend the VD interval (T) period between external VD pulses.

**Note**

Some white spots may appear after a long exposure.

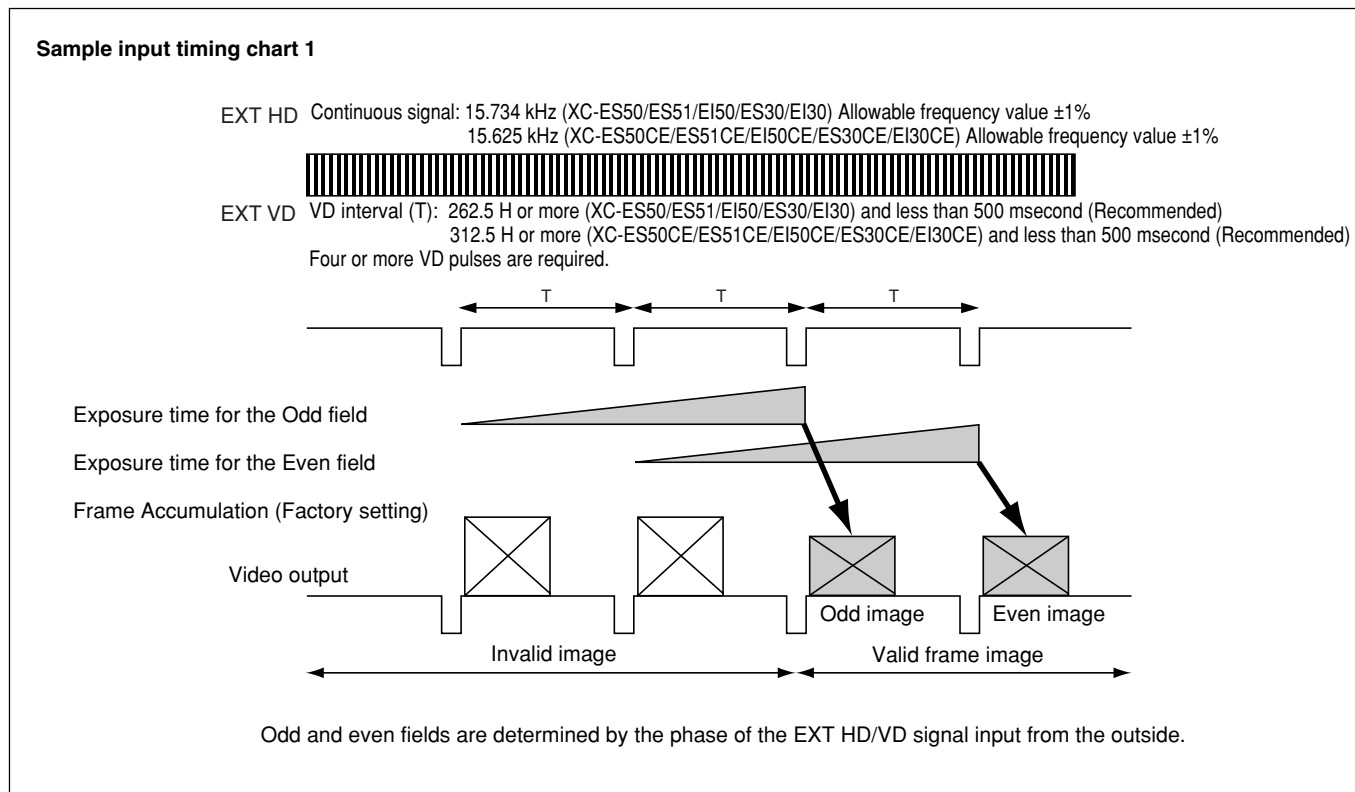

**Sample input timing chart 2**

EXT HD Continuous signal: 15.734 kHz (XC-ES50/ES51/EI50/ES30/EI30) Allowable frequency value  $\pm 1\%$   
 15.625 kHz (XC-ES50CE/ES51CE/EI50CE/ES30CE/EI30CE) Allowable frequency value  $\pm 1\%$

EXT VD VD interval (T): 262.5 H or more (XC-ES50/ES51/EI50/ES30/EI30) and less than 500 msecond (Recommended)  
 312.5 H or more (XC-ES50CE/ES51CE/EI50CE/ES30CE/EI30CE) and less than 500 msecond (Recommended)  
 Four or more VD pulses are required.

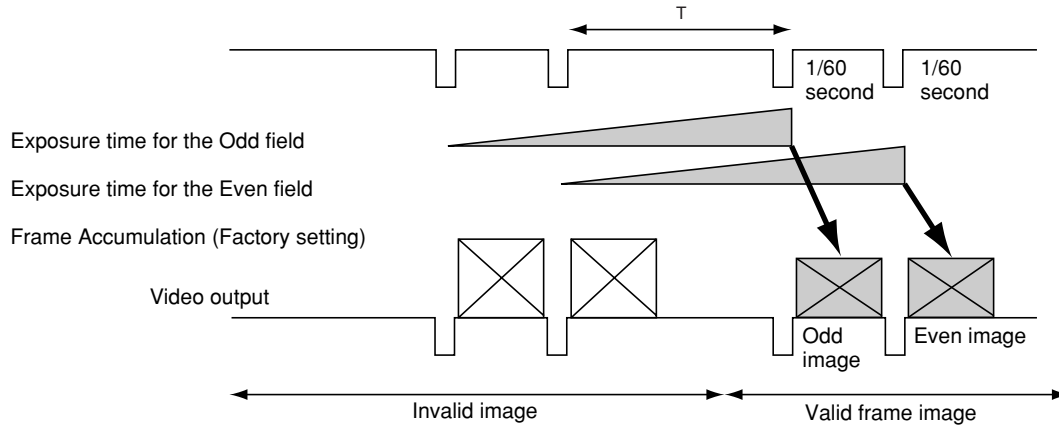

Odd and even fields are determined by the phase of the EXT HD/VD signal input from the outside.  
 When the camera is set to Field Accumulation, images are output based on the field exposure time of the CCD.

**Frame image output with a strobe light**

The factory setting for this camera is Frame Accumulation. The images obtained when the normal continuous shutter or trigger shutter is used are field images (vertical resolution: 243 lines).

Using a strobe light and Restart/Reset mode, you can obtain bright frame images by synchronizing any strobe light. (vertical resolution: 485 lines).

**Sample input timing chart**

EXT HD Continuous signal: 15.734 kHz (XC-ES50/ES51/EI50/ES30/EI30) Allowable frequency value  $\pm 1\%$   
 15.625 kHz (XC-ES50CE/ES51CE/EI50CE/ES30CE/EI30CE) Allowable frequency value  $\pm 1\%$

EXT VD VD: 1/60 sec (XC-ES50/ES51/EI50/ES30/EI30)  
 1/50 sec (XC-ES50CE/ES51CE/EI50CE/ES30CE/EI30CE)  
 Four or more VD pulses are required.

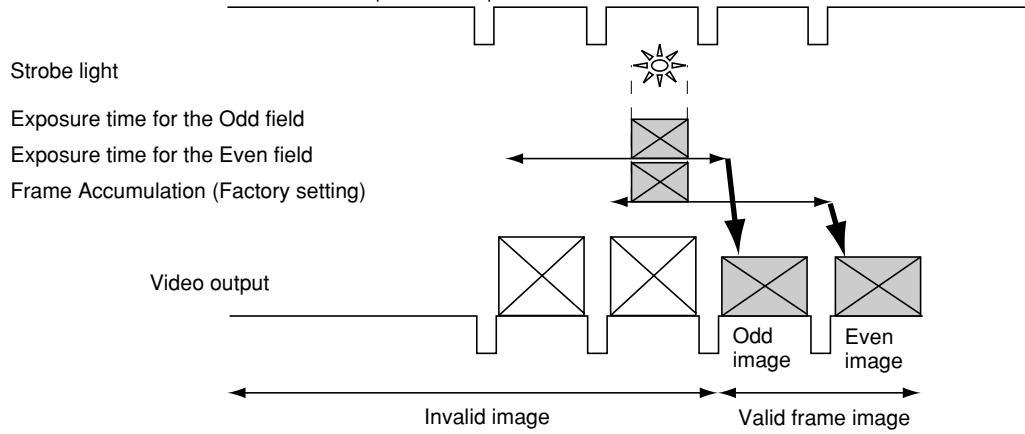

Odd and even fields are determined by the phase of the EXT HD/VD signal input from the outside.  
 Avoid flashing in the light-emitting inhibit zone shown below. (The field is transferred to the storage area of the CCD, so it can be read out.)  
 Light-emitting inhibit zone:  
 Between VD and VD +10 H for XC-ES50/ES51/EI50/ES30/EI30  
 Between VD and VD +16 H for XC-ES50CE/ES51CE/EI50CE/ES30CE/EI30CE

# Timing Charts

## When set to Mode 1

### For setting the shutter speed using the trigger pulse width

#### HD/VD input

#### ◆ Continuous VD input

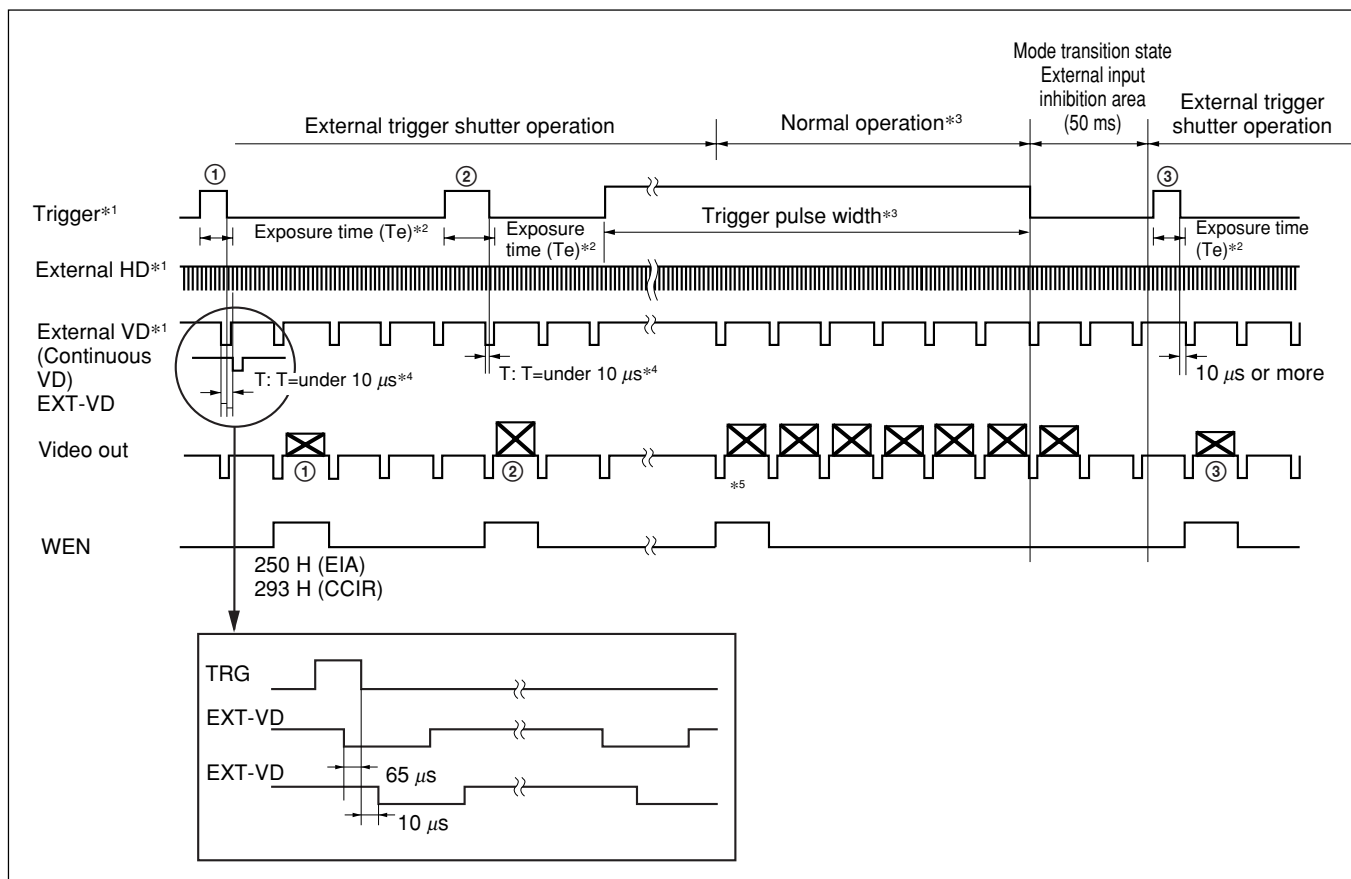

\*1 This is a signal input from outside. Make sure to input both HD and VD signals.

\*2 Exposure time (Te)

Te = Trigger pulse width + 97 μsec (EIA)

Te = Trigger pulse width + 120 μsec (CCIR)

(The effective trigger pulse width for the external trigger shutter operation is between 2 μs and 1/4 s.)

\*3 The normal operation state is chosen when the trigger pulse width is 1/3 s or more. The trigger falling edge restores the external trigger shutter operation. In this case, the area between the falling edge of a trigger pulse and the subsequent 50 ms period is an external trigger input inhibition area. There is no guarantee of operation for any trigger input selected in this period.

\*4 If there is a falling edge on the external VD within a period of -65 to +10 μs from the falling trigger edge (① and ② in the figure), it is not defined whether the image is output for the external VD falling edge or the image is output for the next external VD falling edge. (① in the figure shows that the image is output for the next external VD. ② shows the image for the external VD.) In this case, see WEN since output of the image and WEN make up a pair. In any other cases, the image is output for the external VD falling edge after the trigger falling edge (③ in the figure).

\*5 When the external trigger shutter mode changes to the normal operation mode, one WEN signal is output.

#### Note

An image will not be output correctly if another trigger is input before the image for the previous trigger is output.

## For setting the shutter speed using the trigger pulse width

### HD/VD input

#### ◆ Continuous HD input/Single VD input

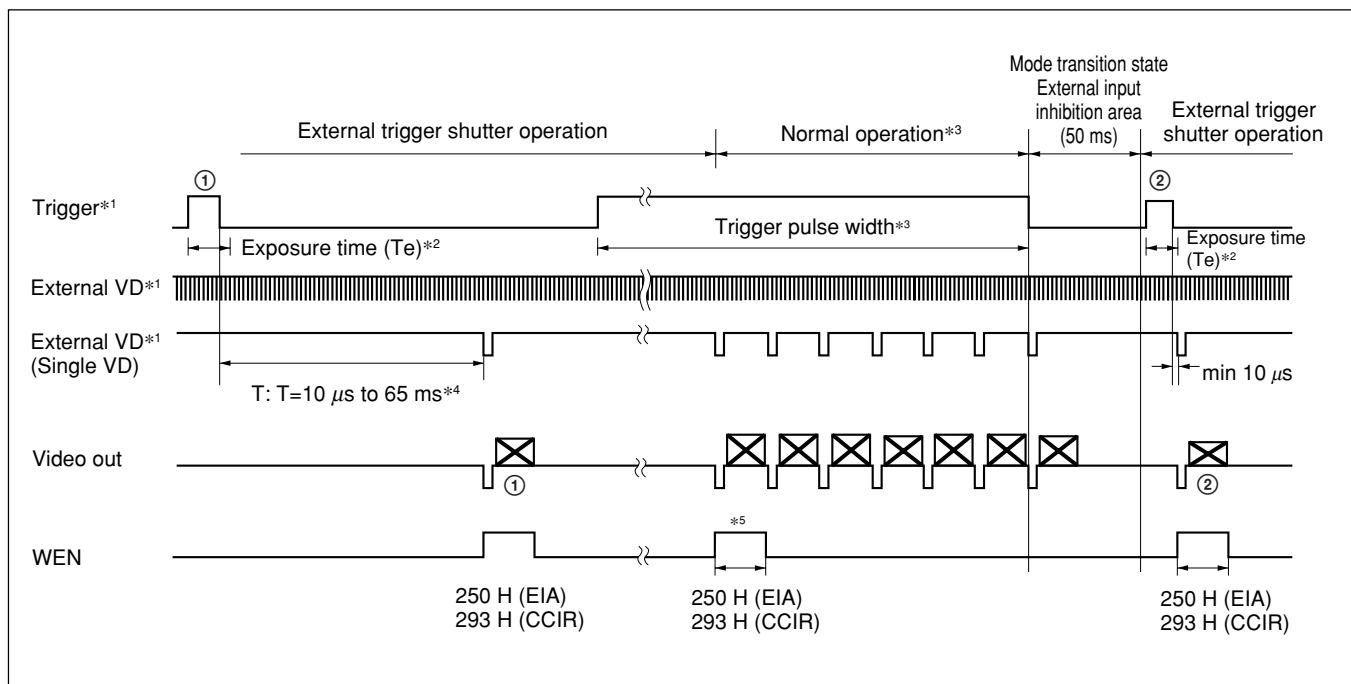

\*1 This is a signal input from outside. Make sure to input both HD and VD signals in this case. Input the signal so that the VD phase aligns with the HD falling edge.

\*2 Exposure time ( $T_e$ )  
 $T_e = \text{Trigger pulse width} + 97 \mu\text{sec (EIA)}$   
 $T_e = \text{Trigger pulse width} + 120 \mu\text{sec (CCIR)}$   
 (The effective trigger pulse width for the external trigger shutter operation is between  $2 \mu\text{s}$  and  $1/4 \text{ s}$ .)

\*3 The normal operation state is chosen when the trigger pulse width is  $1/3 \text{ s}$  or more. (By entering a continuous VD in this section, an image is output.) The trigger falling edge restores the external trigger shutter operation. In this case, the area between the falling edge of a trigger pulse and the subsequent 50 ms period is an external trigger input inhibition area. There is no guarantee of operation for any trigger input selected in this period.

\*4 Input the external VD within the period of  $10 \mu\text{s}$  to  $65 \text{ ms}$  after the trigger falling edge (① and ② in the figure). There is no guarantee of operation when any other input is selected. If an invalid signal is input, the input is changed to a valid signal and, after several V signals, normal operation will resume.

\*5 When the external trigger shutter mode changes to the normal operation mode, one WEN signal is output.

#### Note

Make sure that the trigger signal and the VD signal make up a pair.

An image will not be output correctly if another trigger is input before the image for the previous trigger is output.

## For setting the shutter speed using the trigger pulse width

### No HD/VD input (Internal synchronization)

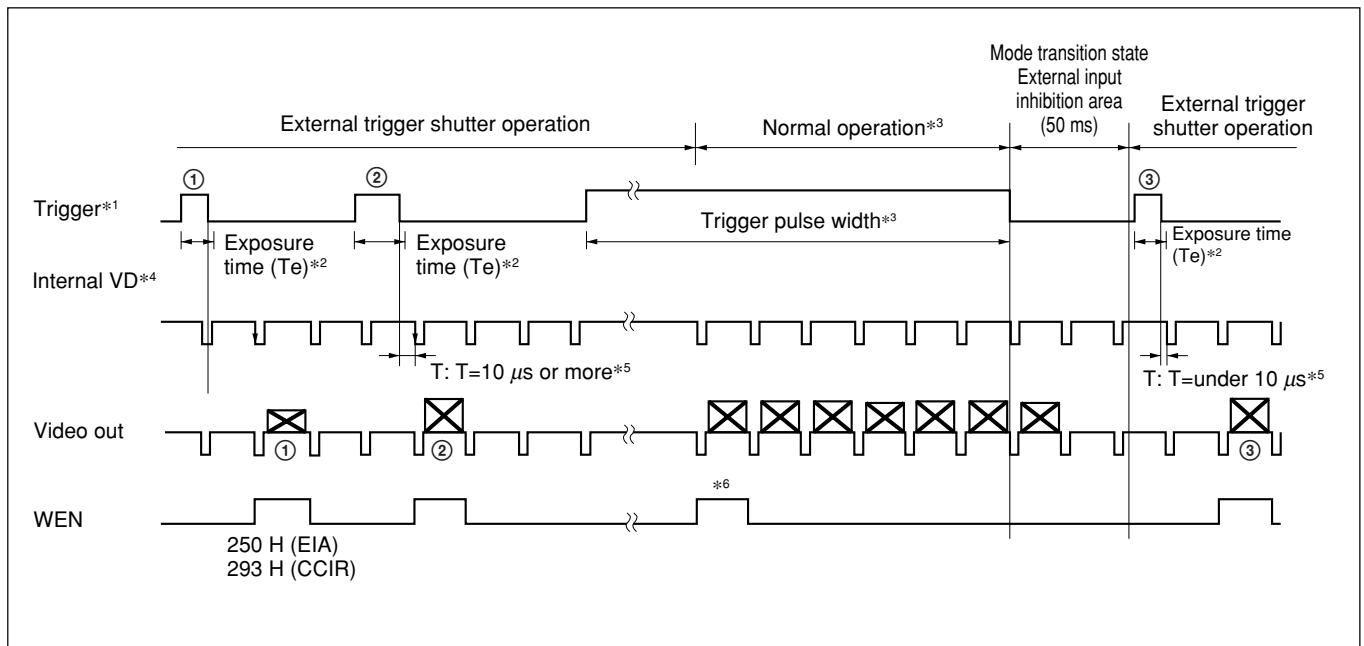

\*1 This is a signal input from outside.

\*2 Exposure time (Te)

Te = Trigger pulse width + 97 μsec (EIA)

Te = Trigger pulse width + 120 μsec (CCIR)

(The effective trigger pulse width for the external trigger shutter operation is between 2 μs and 1/4 s.)

\*3 The normal operation state is chosen when the trigger pulse width is 1/3 s or more. The trigger falling edge restores the external trigger shutter operation. In this case, the area between the falling edge of a trigger pulse and the subsequent 50 ms period is an external trigger input inhibition area. There is no guarantee of operation for any triggers input in this period.

\*4 The internal VD signals are output as long as there is no external input and the HD/VD signal I/O switch on the rear panel is set to INT.

\*5 In the external trigger operation, the image is output for the internal VD falling edge after the trigger falling edge (① and ② in the figure). If the period from the trigger falling edge to the internal VD falling edge (T in the figure) is under 10 μs, there may be a delay of 1 VD in the output. (③ in the figure shows that the image is output for the next internal VD). In this case, see WEN since the image and WEN make up a pair. (The internal VD falling edge and the beginning of the equivalent pause in the V period of the SYNC have the same phase.)

\*6 When the external trigger shutter mode changes to the normal operation mode, one WEN signal is output.

#### Note

An image will not be output correctly if another trigger is input before the image for the previous trigger is output.

## For setting the shutter speed using the DIP switches

### HD/VD input

#### ◆ Continuous VD input

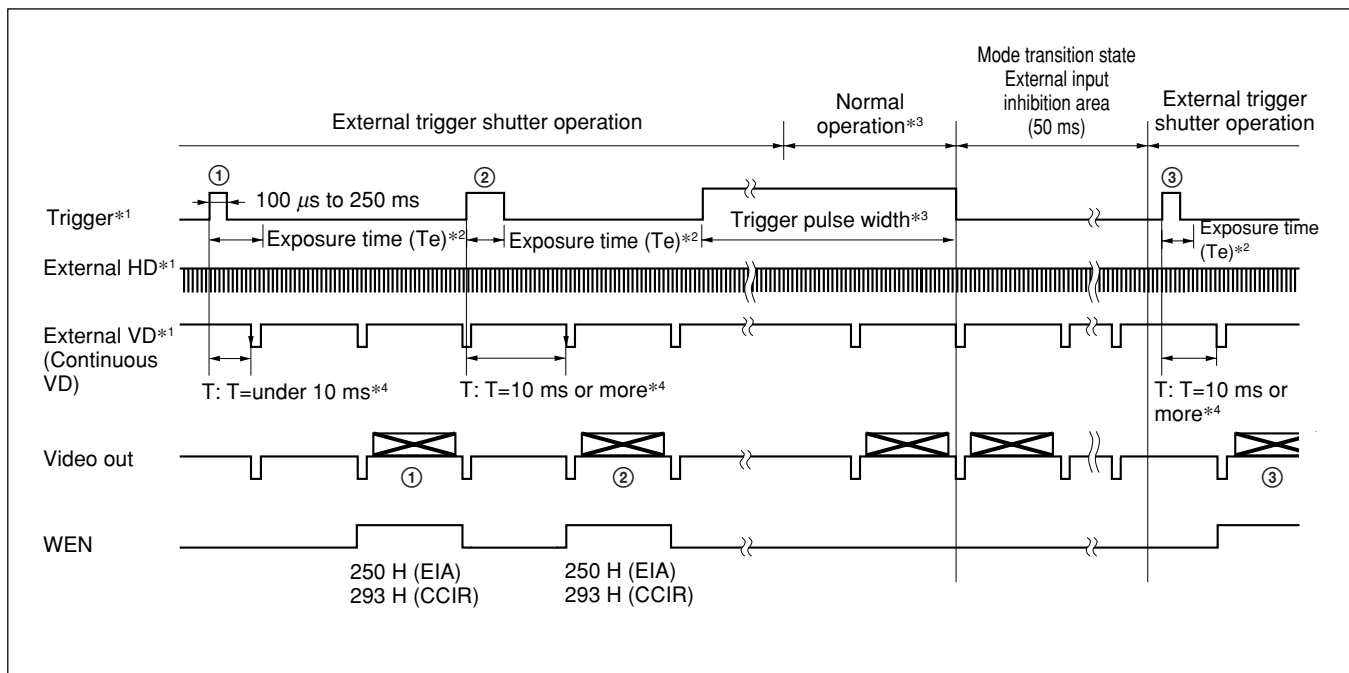

\*1 This is a signal input from outside. The continuous VD frequency is one field. Make sure you input HD and VD at the same time.

\*2 The exposure time (Te) is determined by the setting of the DIP switches.  
For details, see Page 10.

\*3 The normal operation state is chosen when the trigger pulse width is 1/3 s or more. The trigger falling edge restores the external trigger shutter operation. In this case, the area between the falling edge of a trigger pulse and the subsequent 50 ms period is an external trigger input inhibition area. There is no guarantee of operation for any triggers input in this period.

\*4 An image is output when an external VD signal falls 10 ms or more after a trigger pulse rises (2 and 3 in the figure). If the period from the trigger rising edge to the external VD falling edge (T in the figure) is under 10 ms, there may be a delay of 1 VD in the output. (1 in the figure shows that the image is output for the next external VD). In this case, see WEN since the image and WEN make up a pair.

#### Note

An image will not be output correctly if another trigger is input before the image for the previous trigger is output.

## For setting the shutter speed using the DIP switches

### HD/VD input

#### ◆ Continuous HD input/Single VD input

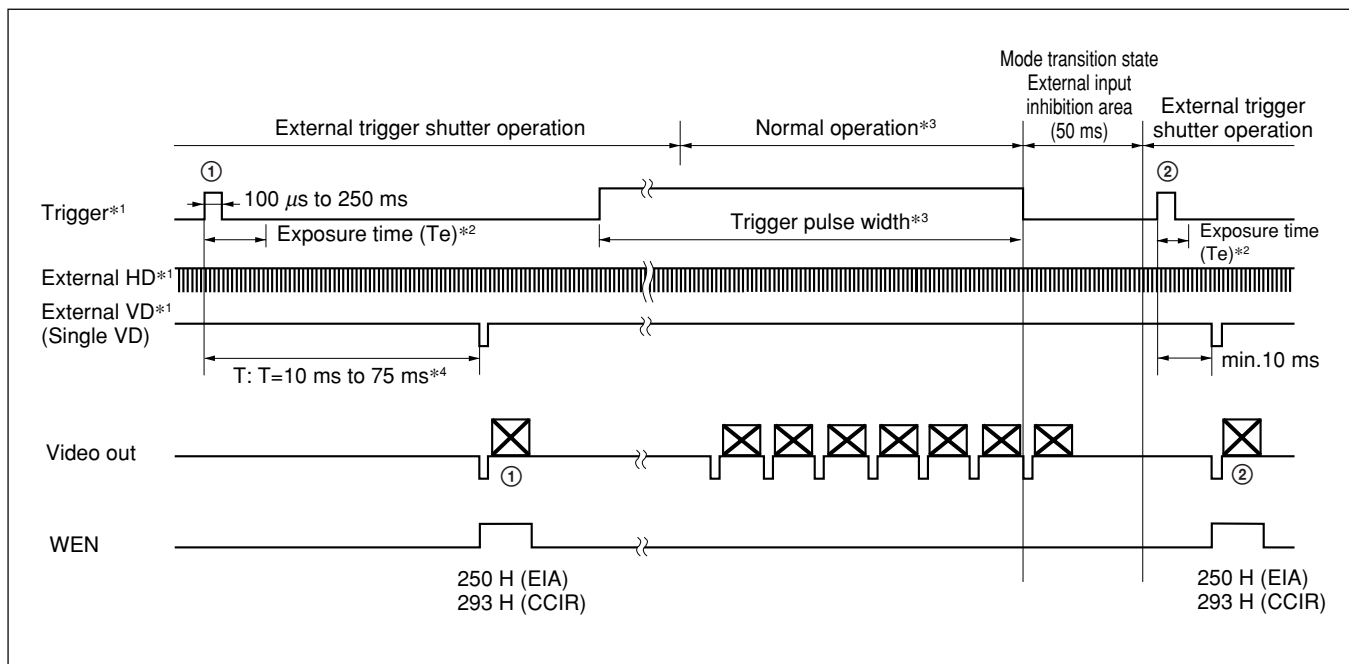

\*1 This is a signal input from outside. Make sure to input both HD and VD signals in this case. Input the signal so that the VD phase aligns with the HD falling edge.

\*2 The exposure time ( $T_e$ ) is determined by the setting of the DIP switches.  
For details, see Page 10.

\*3 The normal operation state is chosen when the trigger pulse width is 1/3 s or more. (By entering a continuous VD in this section, an image is output.) The trigger falling edge restores the external trigger shutter operation. In this case, the area between the falling edge of a trigger pulse and the subsequent 50 ms period is an external trigger input inhibition area. There is no guarantee of operation for any triggers input in this period.

\*4 Input the external VD within the period of 10 ms to 75 ms after the trigger rising edge (① and ② in the figure). There is no guarantee of operation when any other input is selected. If an invalid signal is input, the input is changed to a valid signal, and after several V signals, normal operation will resume.

#### Note

Make sure that the trigger signal and the VD signal make up a pair.  
An image will not be output correctly if another trigger is input before the image for the previous trigger is output.

## For setting the shutter speed using the DIP switches

### No HD/VD input (Internal synchronization)

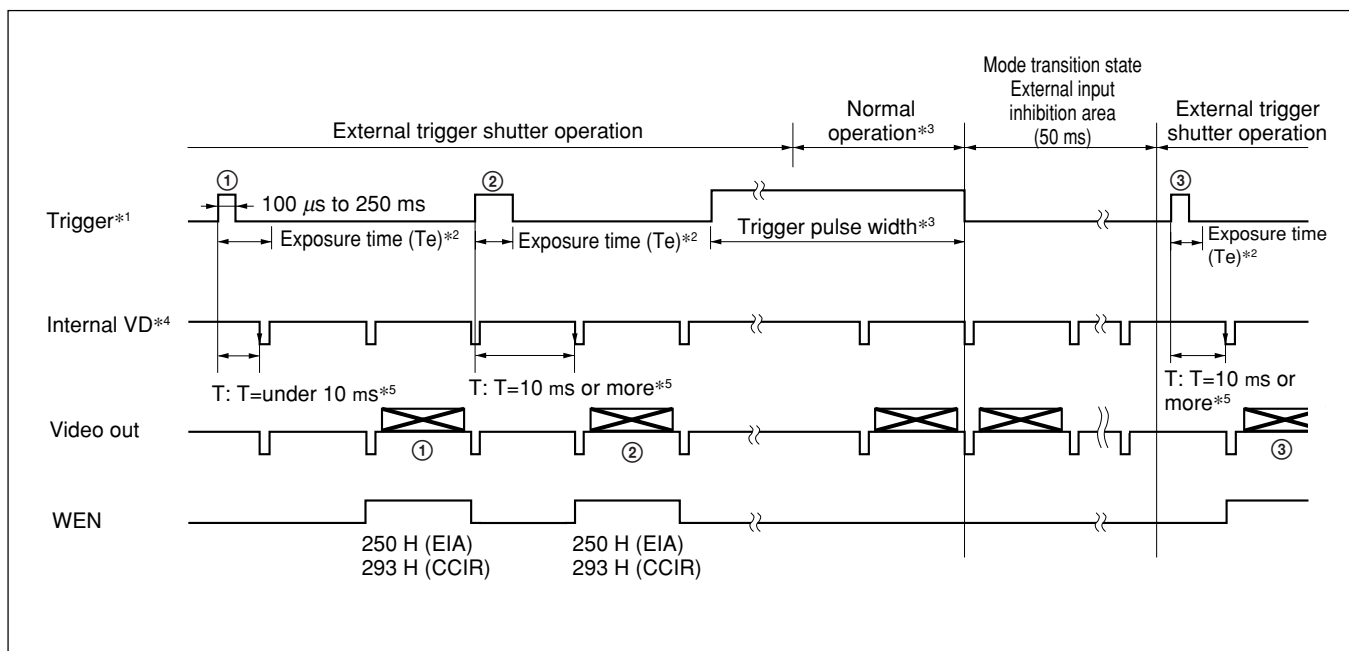

\*1 This is a signal input from outside.

\*2 The exposure time (Te) is determined by the setting of the DIP switches.  
For details, see Page 10.

\*3 The normal operation state is chosen when the trigger pulse width is 1/3 s or more. The trigger falling edge restores the external trigger shutter operation. In this case, the area between the falling edge of a trigger pulse and the subsequent 50 ms period is an external trigger input inhibition area. There is no guarantee of operation for any triggers input in this period.

\*4 The internal VD signals are output as long as there is no external input and the HD/VD signal input/output switch on the rear panel is set to INT.

\*5 An image is output when an internal VD signal falls 10 ms or more after a trigger pulse rises (② and ③ in the figure). If the period from the trigger rising edge to the internal VD falling edge (T in the figure) is under 10 ms, it is not defined whether the image is output for the internal VD falling edge or the image is output for the next internal VD falling edge. (① in the figure shows that the image is output for the next internal VD). In this case, see WEN since the image and WEN make up a pair. (The internal VD falling edge and the beginning of the equivalent pause in the V period of the SYNC have the same phase.)

#### Note

An image will not be output correctly if another trigger is input before the image for the previous trigger is output.

## When set to Mode 2

### For setting the shutter speed using the trigger pulse width

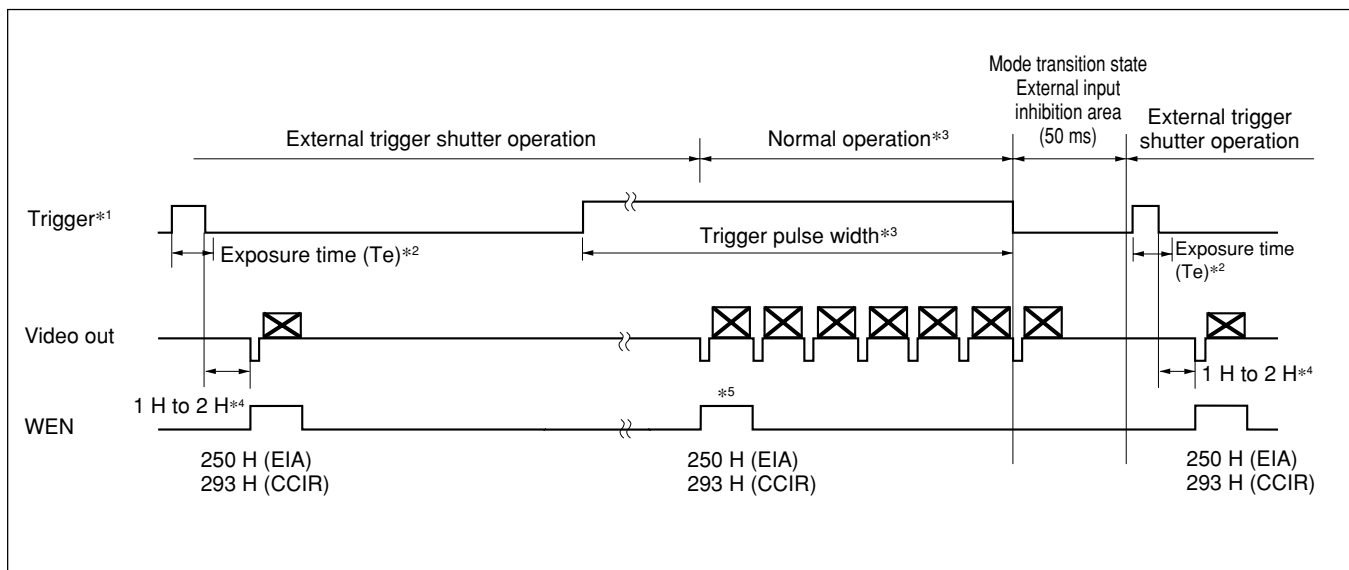

\*1 This is a signal input from outside. The trigger input frequency must be [Trigger pulse width + 1 field + 2 H frequency] or more. The operation is not guaranteed for shorter frequencies. If invalid data is input, normal operation is resumed several Vs after entering the correct data.

\*2 Exposure time (Te)  
 $Te = \text{Trigger pulse width} + 97 \mu\text{sec (EIA)}$   
 $Te = \text{Trigger pulse width} + 120 \mu\text{sec (CCIR)}$   
 (The effective trigger pulse width for the external trigger shutter operation is between  $2 \mu\text{s}$  and  $1/4 \text{ s}$ .)

\*3 The normal operation state is chosen when the trigger pulse width is  $1/3 \text{ s}$  or more. The trigger falling edge restores the external trigger shutter operation. In this case, the area between the falling edge of a trigger pulse and the subsequent 50 ms period is an external trigger input inhibition area. There is no guarantee of operation for any triggers input in this period.

\*4 A VD signal is generated after 1 H to 2 H from the trigger falling edge, then the image is output synchronized with the VD generation.

\*5 When the external trigger shutter mode changes to the normal operation mode, one WEN signal is output.

## For setting the shutter speed using the DIP switches

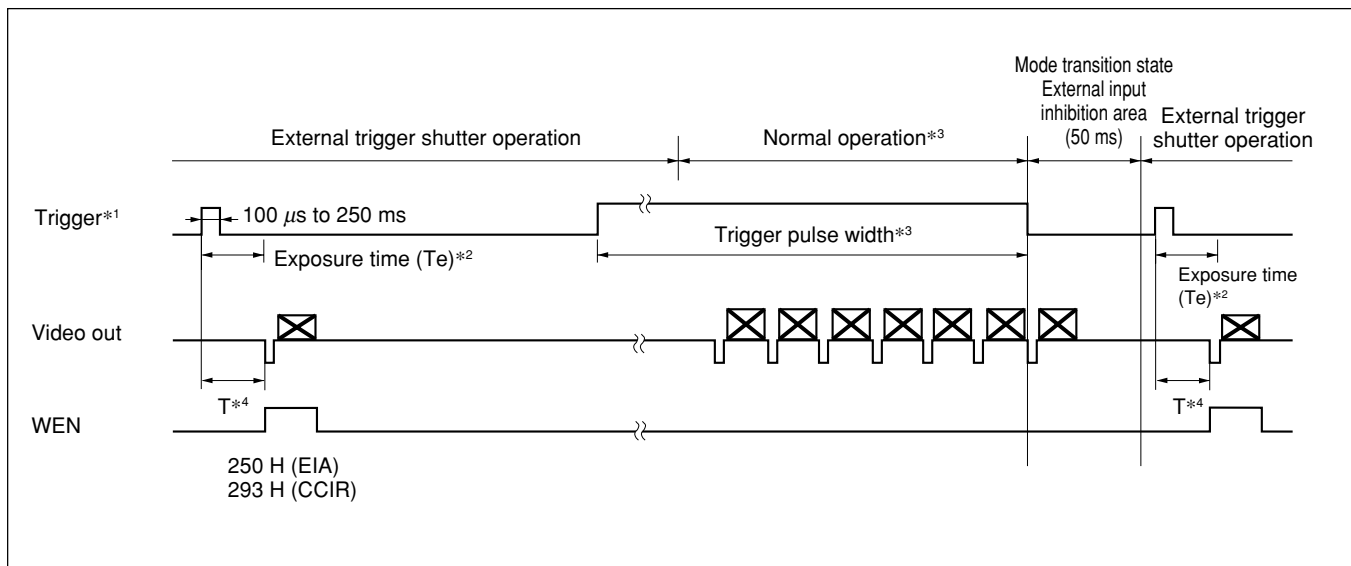

\*1 This is a signal input from outside. The trigger input frequency must be [Shutter speed (DIP switches) + 1 field + 2 H frequency] or more. If invalid data is input, normal operation is resumed several Vs after entering the correct data.

\*2 The exposure time (Te) is determined by the setting of the DIP switches.  
*For details, see Page 10.*

\*3 The normal operation state is chosen when the trigger pulse width is 1/3 s or more. The trigger falling edge restores the external trigger shutter operation. In this case, the area between the falling edge of a trigger pulse and the subsequent 50 ms period is an external trigger input inhibition area. There is no guarantee of operation for any triggers input in this period.

\*4 The image is output at the shortest timing from the trigger rising edge according to the DIP switch setting.

# Appendix

## Specifications

Image pickup device	XC-ES50/50CE, XC-ES51/51CE, XC-EI50/50CE: 1/2 type interline transfer CCD XC-ES30/30CE, XC-EI30/30CE: 1/3 type interline transfer CCD	Chip size	XC-ES50/ES51/EI50: 7.4 (H) × 5.95 (V) mm XC-ES50CE/ES51CE/EI50CE: 7.4 (H) × 5.95 (V) mm XC-ES30: 5.59 (H) × 4.68 (V) mm XC-ES30CE: 5.59 (H) × 4.68 (V) mm XC-EI30: 6.00 (H) × 4.96 (V) mm XC-EI30CE: 6.00 (H) × 4.96 (V) mm
Number of effective pixels	XC-ES50/EI50/ES51: 768 (H) × 494 (V) XC-ES30/EI30: 768 (H) × 494 (V) XC-ES50CE/EI50CE/ES51CE: 752 (H) × 582 (V) XC-ES30CE/EI30CE: 752 (H) × 582 (V)	Lens mount	C-mount
CCD horizontal driving frequency	XC-ES50/EI50/ES51: 14.318 MHz XC-ES30/EI30: 14.318 MHz XC-ES50CE/EI50CE/ES51CE: 14.187 MHz XC-ES30CE/EI30CE: 14.187 MHz	Flange back	17.526 mm ( <sup>23</sup> / <sub>32</sub> inches)
CCD vertical driving frequency	XC-ES50/EI50/ES51: 15.734 kHz ± 1% XC-ES30/EI30: 15.734 kHz ± 1% XC-ES50CE/EI50CE/ES51CE: 15.625 kHz ± 1% XC-ES30CE/EI30CE: 15.625 kHz ± 1%	Synchronization system	Internal/External (Selected automatically)
Signal system	EIA/CCIR	External synchronization input/output	HD/VD (2 to 5 Vp-p) * Automatically selected according to the existence of an input signal when the switch on the rear panel is set to EXT.
Cell size	XC-ES50/EI50/ES51: 8.4 (H) × 9.8 (V) μm XC-ES50CE/EI50CE/ES51CE: 8.6 (H) × 8.3 (V) μm XC-ES30/EI30: 6.35 (H) × 7.4 (V) μm XC-ES30CE/EI30CE: 6.5 (H) × 6.25 (V) μm	Allowable frequency deviation of external synchronization	±1% (in horizontal synchronous frequency)
		Jitter	Within ±50 nsec.
		Scanning system	2:1 interlace/noninterlace (automatically switched according to external input signal)
		Horizontal resolution	XC-ES50/EI50/ES51: 570 TV lines XC-ES30/EI30: 570 TV lines XC-ES50CE/EI50CE/ES51CE: 560 TV lines XC-ES30CE/EI30CE: 560 TV lines
		Sensitivity (γ=ON, MIN GAIN, without IR cut filter)	XC-ES51/51CE: 400 lx F8 XC-ES50/50CE: 400 lx F5.6 XC-ES30/30CE: 400 lx F4 XC-EI50/50CE: 400 lx F11 XC-EI30/30CE: 400 lx F8

S/N ratio	60 dB
Minimum illuminance (F1.4, $\gamma$ =ON, MAX GAIN, without IR cut filter)	XC-ES50/50CE, XC-ES30/30CE: 0.3 lx XC-ES51/51CE: 0.2 lx XC-EI50/50CE: 0.1 lx XC-EI30/30CE: 0.2 lx
Gain	AGC/Manual (Can be selected using the switch on the rear panel)
Gamma compensation	ON/OFF (Can be selected using the switch on the rear panel)
Electronic shutter	XC-ES50/EI50/ES51: 1/100 to 1/10,000 second XC-ES30/EI30: 1/100 to 1/10,000 second XC-ES50CE/EI50CE/ES51CE: 1/120 to 1/10,000 second XC-ES30CE/EI30CE: 1/120 to 1/10,000 second
External trigger shutter	XC-ES50/EI50/ES51: 1/4 to 1/10,000 second XC-ES30/EI30: 1/4 to 1/10,000 second XC-ES50CE/EI50CE/ES51CE: 1/4 to 1/8,000 second XC-ES30CE/EI30CE: 1/4 to 1/8,000 second * Can be changed using the trigger pulse width or set using the DIP switches on the rear panel.
Power requirement	DC +12 V (+9.0 V to 16 V)
Power consumption	XC-ES30/30CE, XC-EI30/30CE: 1.4 W XC-ES50/50CE, XC-EI50/50CE, XC-ES51/51CE: 1.6 W
Operating temperature	-5 °C to +45 °C (23 °F to 113 °F)
Storage temperature	-20 °C to +60 °C (-4 °F to 140 °F)
Performance assurance temperature	0 °C to +30 °C (32 °F to 86 °F)
Operating humidity	20 to 80% (Non-condensing)
Storage humidity	20 to 95% (Non-condensing)
Vibration resistance	10 G (For 20 minutes in the X, Y and Z directions at 20 to 200 Hz)

Shock resistance	70 G
Outside dimensions	29 (W) × 29 (H) × 30 (D) mm (1 <sup>3</sup> / <sub>16</sub> (W) × 1 <sup>3</sup> / <sub>16</sub> (H) × 1 <sup>3</sup> / <sub>16</sub> (D) inches)
Weight	50 g (2 oz)
Standards	UL1492, FCC Class B Digital Device, CE (EN50081-2+EN50082-2)
Accessories	Lens mount cap (1) Operating Instructions (1)
MTBF	126,469 H (approx. 14.4 years)

\* Note on using the XC-EI50/EI50CE, EI30/EI30CE:  
The output levels for the odd field and the even field may differ in frame accumulation mode.

External synchronization for each mode

Mode		Internal sync	External sync
			HD/VD
Normal		○	○
Normal shutter		○	○
External trigger shutter	Mode 1	○	○
	Mode 2	Trigger signal generates an internal VD signal (single).	×
Restart/reset		×	○

○: Available  
×: Not available

## Specifications tables

	XC-ES50	XC-ES51	XC-EI50	XC-ES30	XC-EI30
Image pickup device	1/2 type interline CCD			1/3 type interline CCD	
Effective pixels	768(H) × 494(V)			768(H) × 494(V)	
Lens mount	C-mount			C-mount	
Scanning system	2:1 interlace			2:1 interlace	
Sensitivity <sup>1)</sup>	400 lx F5.6	400 lx F8	400 lx F11	400 lx F4	400 lx F8
Minimum illuminance <sup>2)</sup>	0.3 lx	0.2 lx	0.1 lx	0.3 lx	0.2 lx
Normal shutter	1/100 to 1/10,000 sec.			1/100 to 1/10,000 sec.	
External trigger shutter	1/4 to 1/10,000 sec.			1/4 to 1/10,000 sec.	
Outside dimensions	29 (W) × 29 (H) × 30 (D) mm			29 (W) × 29 (H) × 30 (D) mm	
Weight	50 g			50 g	
Vibration resistance	10 G (at 20 to 200 Hz, in the X,Y and Z directions)			10 G (at 20 to 200 Hz, in the X,Y and Z directions)	

1)  $\gamma$ =ON, MIN GAIN, without IR cut filter

2) F1.4,  $\gamma$ =ON, MAX GAIN, without IR cut filter

## Various Lens Selection

The following shows the various lens specifications of the accessories available.

### XC-ES50/50CE, XC-ES51/51CE, XC-EI50/50CE, and XC-ES30/30CE, XC-EI30/30CE compatibility

List of C-Mount Lens

Model name		VCL-08YM	VCL-12YM	VCL-16Y-M	VCL-25Y-M	VCL-50Y-M
Focal distance (mm)		8	12	16	25	50
Maximum aperture ratio		1: 1.4	1: 1.8	1: 1.4	1: 1.6	1: 2.8
Operation	Iris	Manual	Manual	Manual	Manual	Manual
	Focus	Manual	Manual	Manual	Manual	Manual
Field angle (Horizontal x vertical)	1/2" CCD	42.6° × 32.6°	29.6° × 22.4°	22.6° × 17.0°	14.6° × 11.0°	7.3° × 5.5°
	1/3" CCD	32.6° × 24.8°	22.4° × 16.9°	17.0° × 12.8°	11.0° × 8.2°	5.5° × 4.1°
MOD (mm)		207	208	289	204	438
Image pickup range during maximum proximity (horizontal × vertical) (mm)	XC-ES50/ES51/EI50	181 × 132.8	125.2 × 92.1	119.4 × 88.5	52.1 × 38.8	49.2 × 37
	XC-ES50CE/ES51CE/EI50CE	181.3 × 133.3	125.5 × 92.5	119.6 × 88.8	52.1 × 38.9	49.7 × 37.1
	XC-ES30/EI30	136.8 × 100	94.7 × 69.6	90 × 66.8	39.4 × 29.3	37.2 × 27.9
	XC-ES30CE/EI30CE	137 × 100.3	94.8 × 69.6	90.4 × 66.9	39.4 × 29.3	37.5 × 27.9
Back focus (mm)		11.54	10.99	12.5	11.6	22.1
Flange back (mm)		17.526	17.526	17.526	17.526	17.526
Mass (g)		40	40	50	42	50

MOD: Minimum object distance between the tip of the lens body and the object.

# Dimensions

## XC-ES50/50CE/ES30/30CE/ ES51/51CE/EI50/50CE/EI30/ 30CE

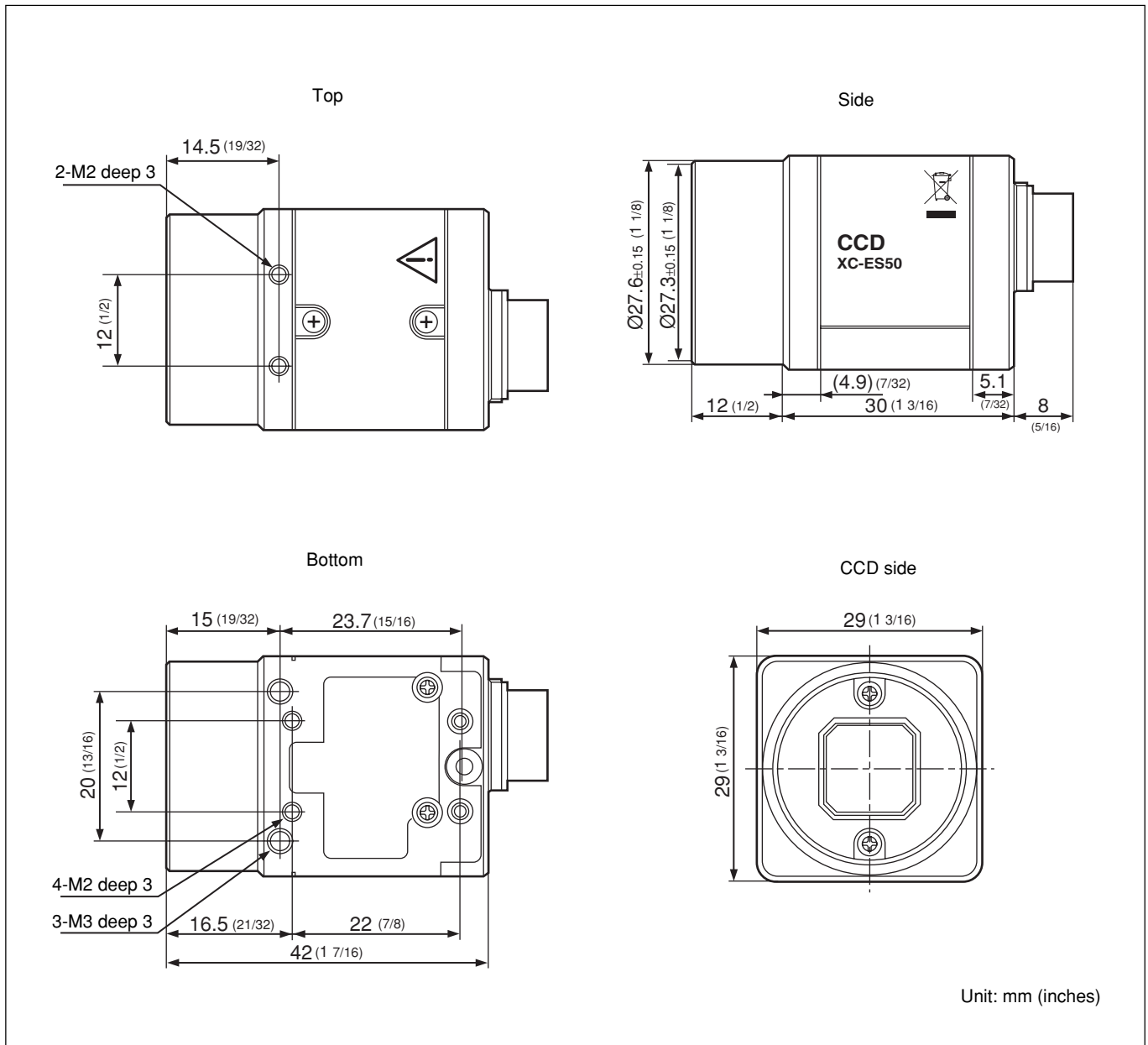

### Note

The dimensions shown above are for the models with the following serial numbers.  
 XC-ES50/EI50/ES30/EI30: 250001 or later.  
 XC-ES51: 150001 or later.  
 XC-ES50CE/EI50CE/ES30CE/EI30CE:  
 550001 or later.  
 XC-ES51CE: 450001 or later.

# Spectral Sensitivity Characteristics

(Lens characteristics included, and light source characteristics excluded)

## XC-ES30

Relative Response

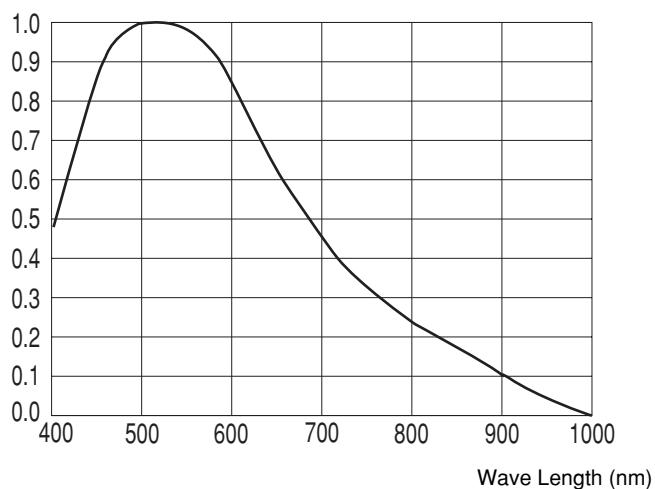

## XC-ES30CE

Relative Response

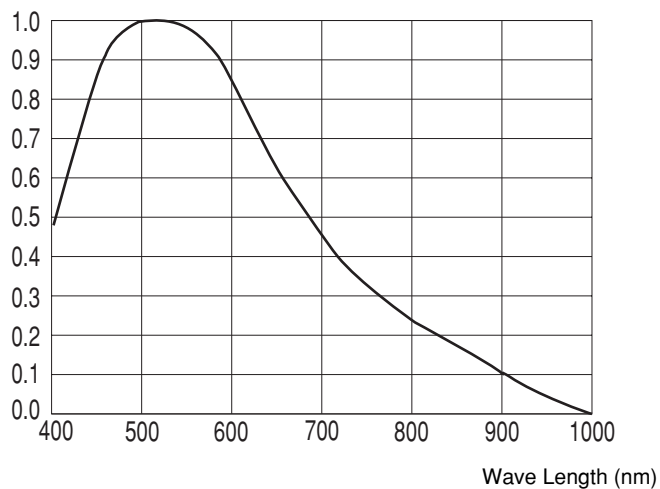

## XC-ES50/ES51

Relative Response

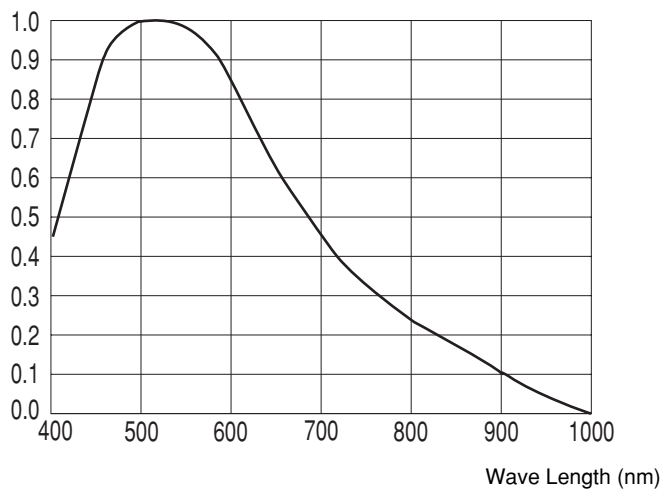

## XC-ES50CE/ES51CE

Relative Response

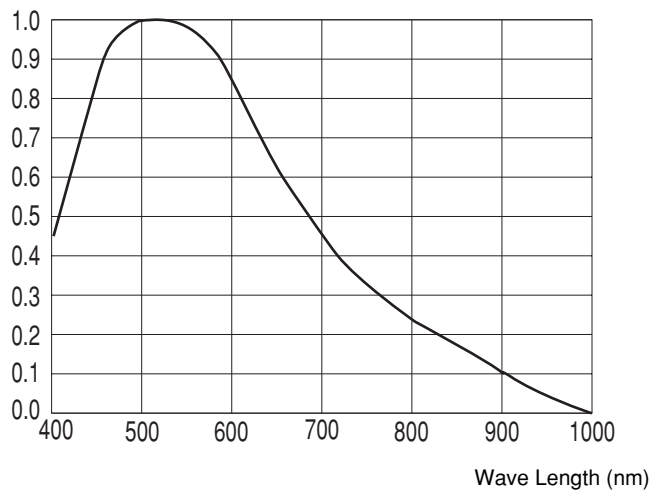

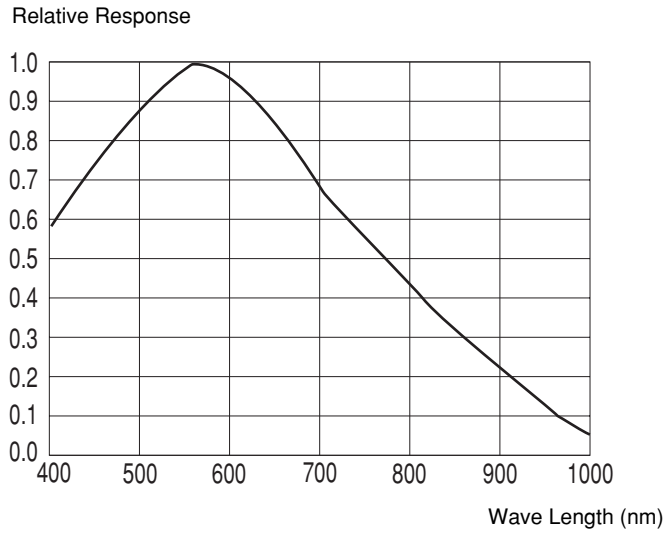
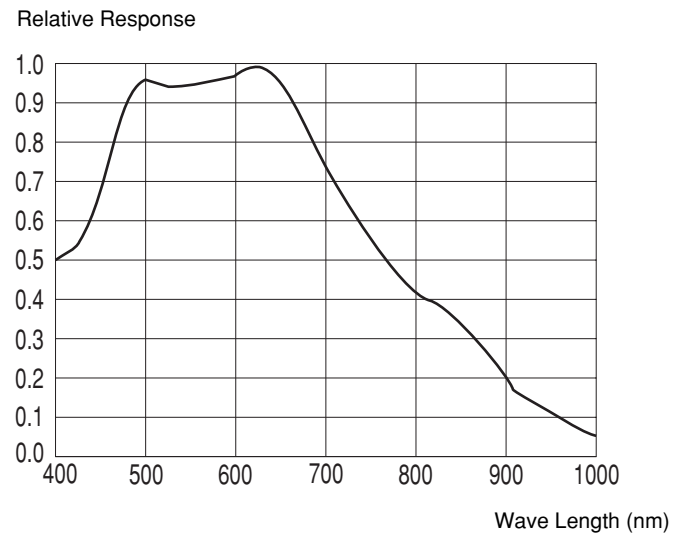
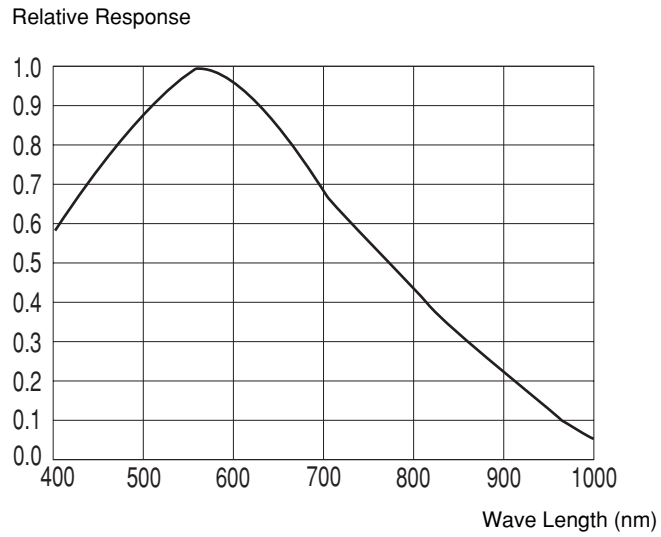
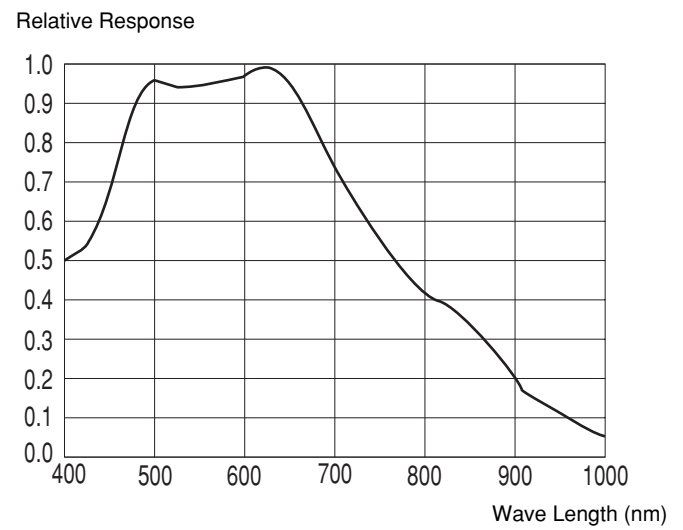
**XC-EI30****XC-EI50****XC-EI30CE****XC-EI50CE**

# CCD Output Waveform Timing Chart

XC-ES50/ES51/EI50/ES30/EI30

## Horizontal Output Waveform Timing Chart

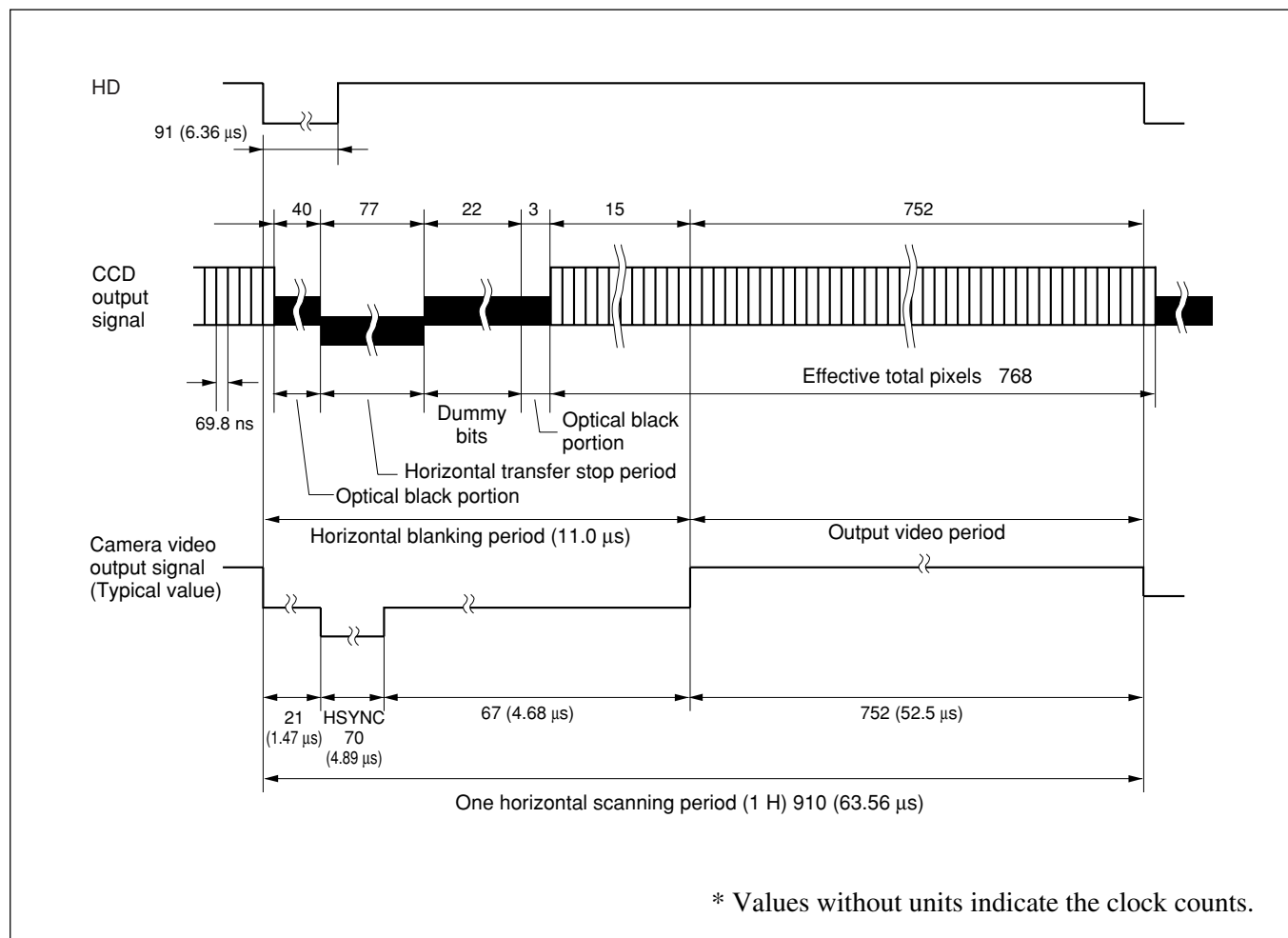

### Vertical Output Waveform Timing Chart (2:1 interlaced frame accumulation)

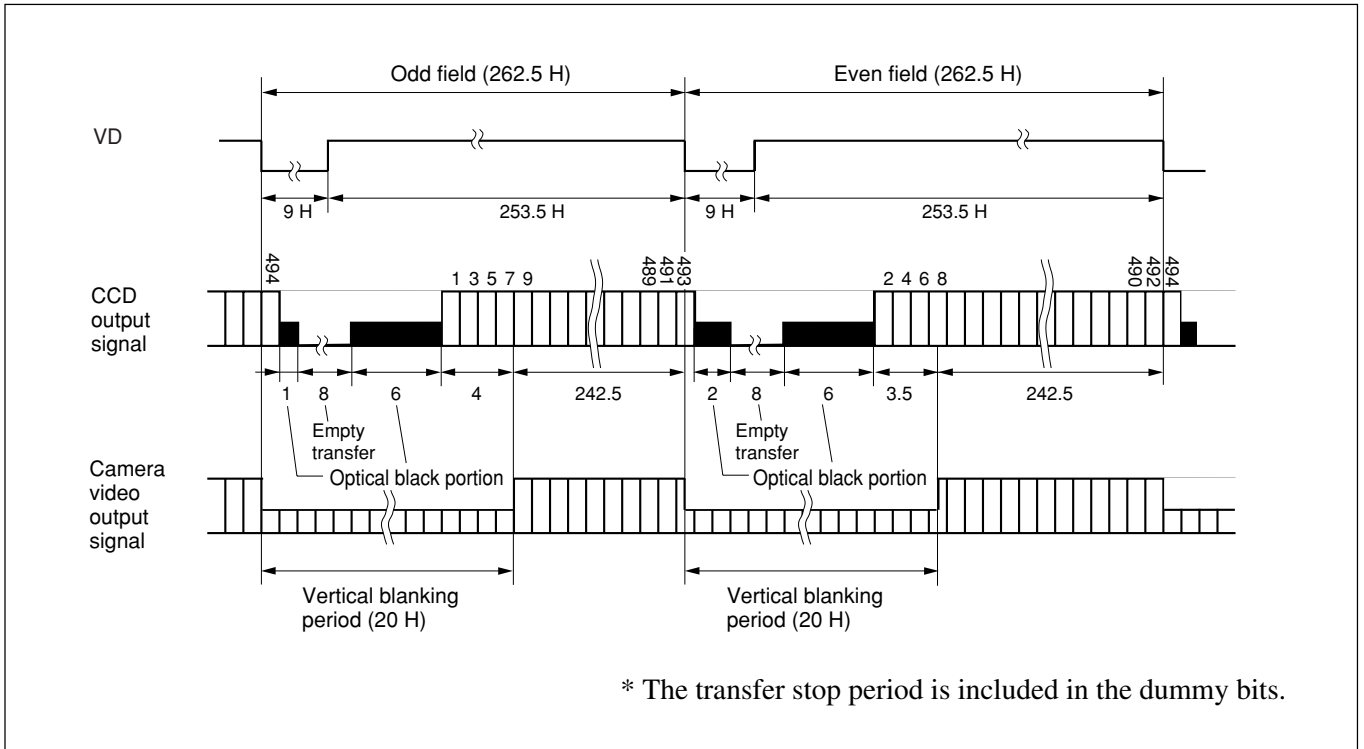

### Vertical Output Waveform Timing Chart (2:1 interlaced field accumulation)

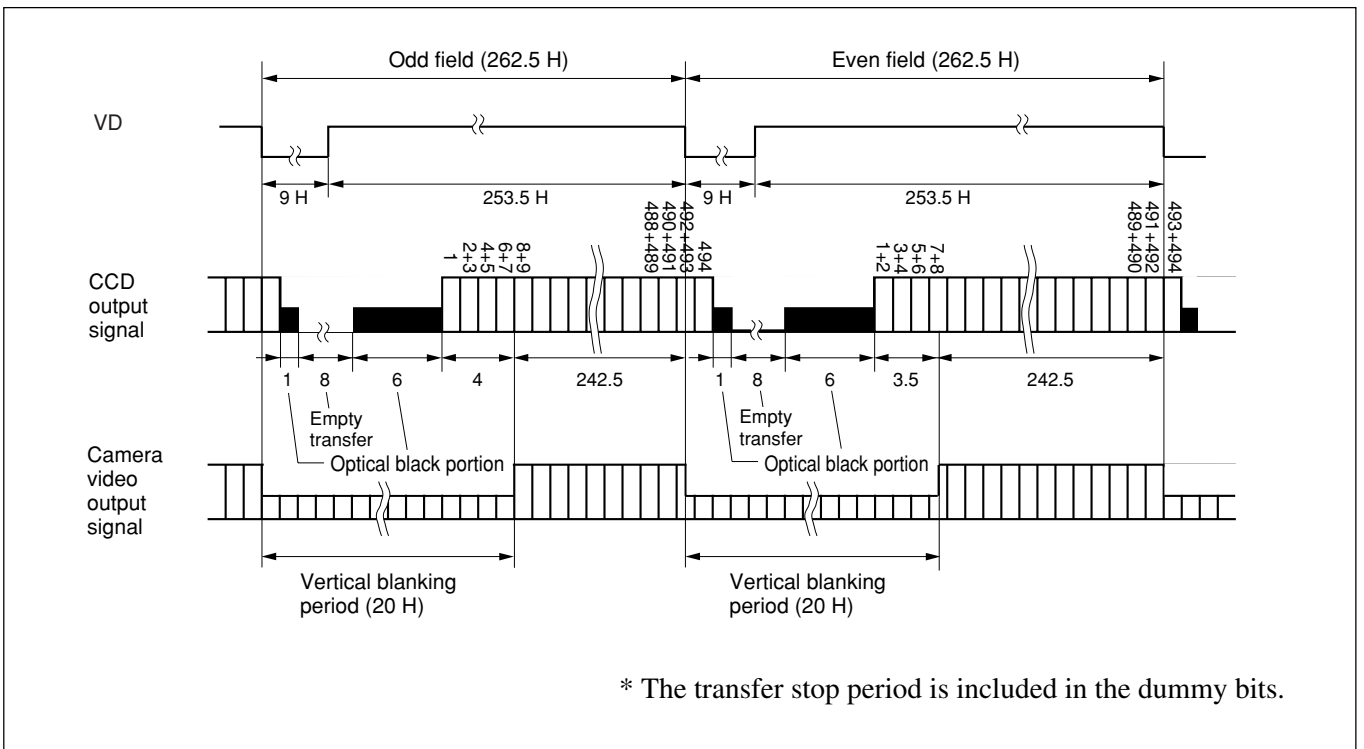

# XC-ES50CE/ES51CE/EI50CE/ES30CE/EI30CE

## Horizontal Output Waveform Timing Chart

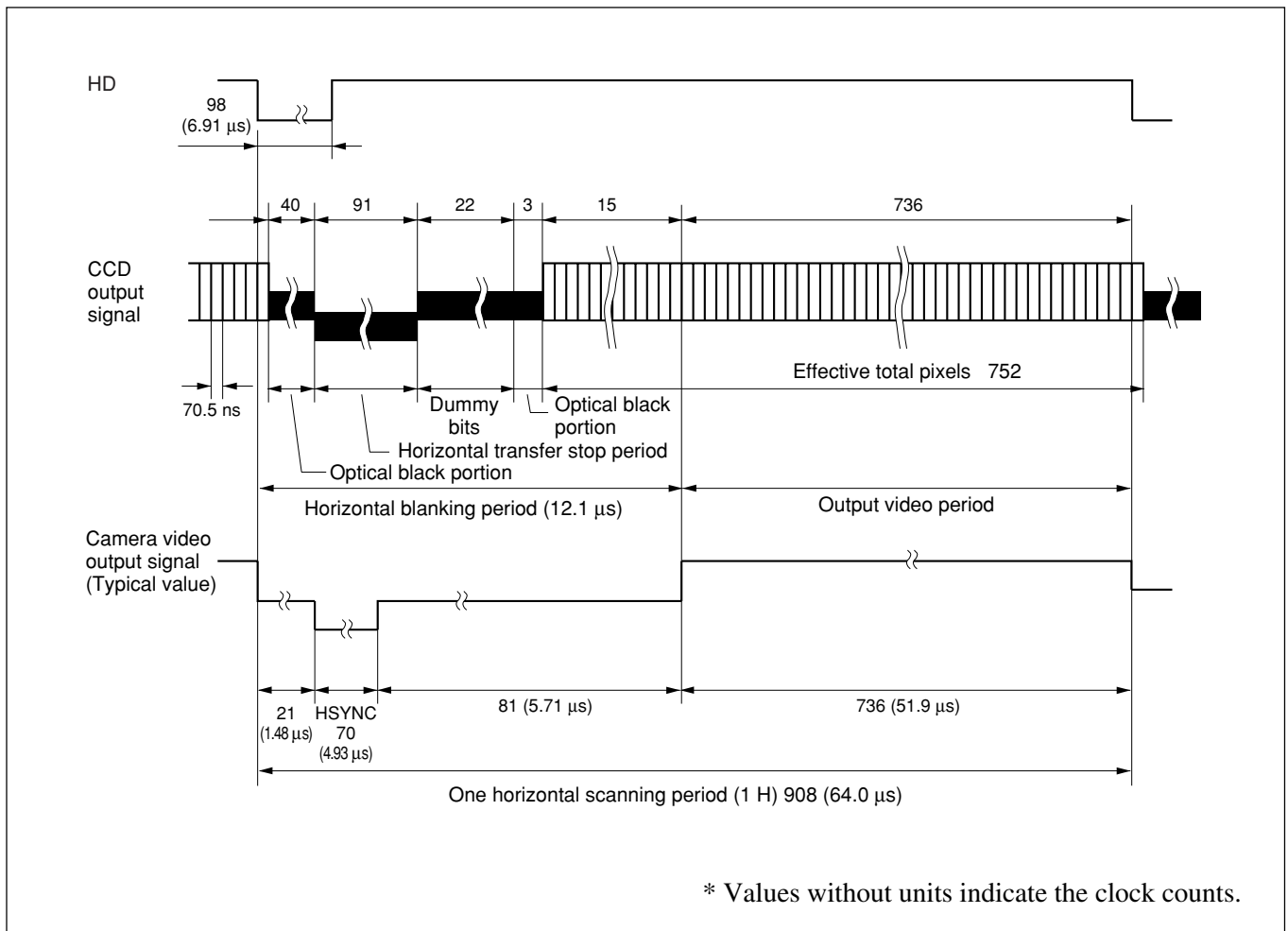

### Vertical Output Waveform Timing Chart (2:1 interlaced frame accumulation)

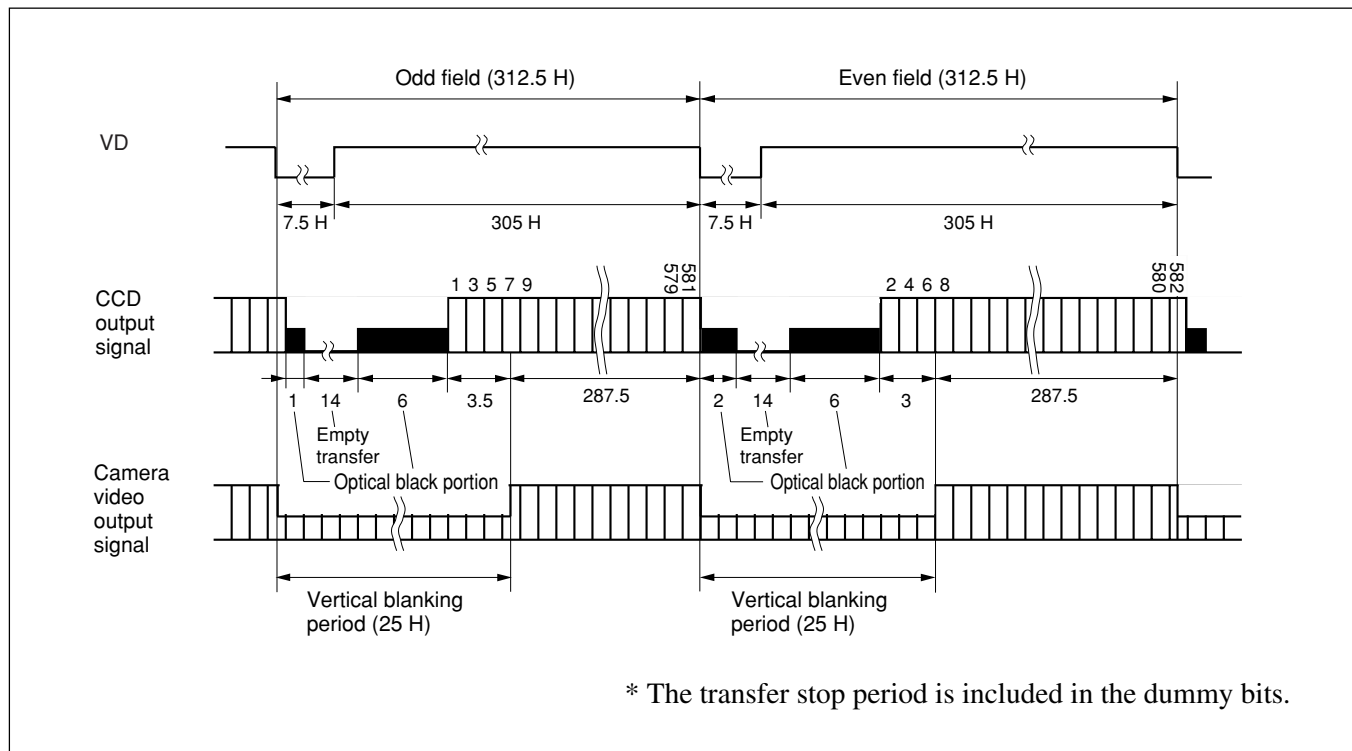

### Vertical Output Waveform Timing Chart (2:1 interlaced field accumulation)

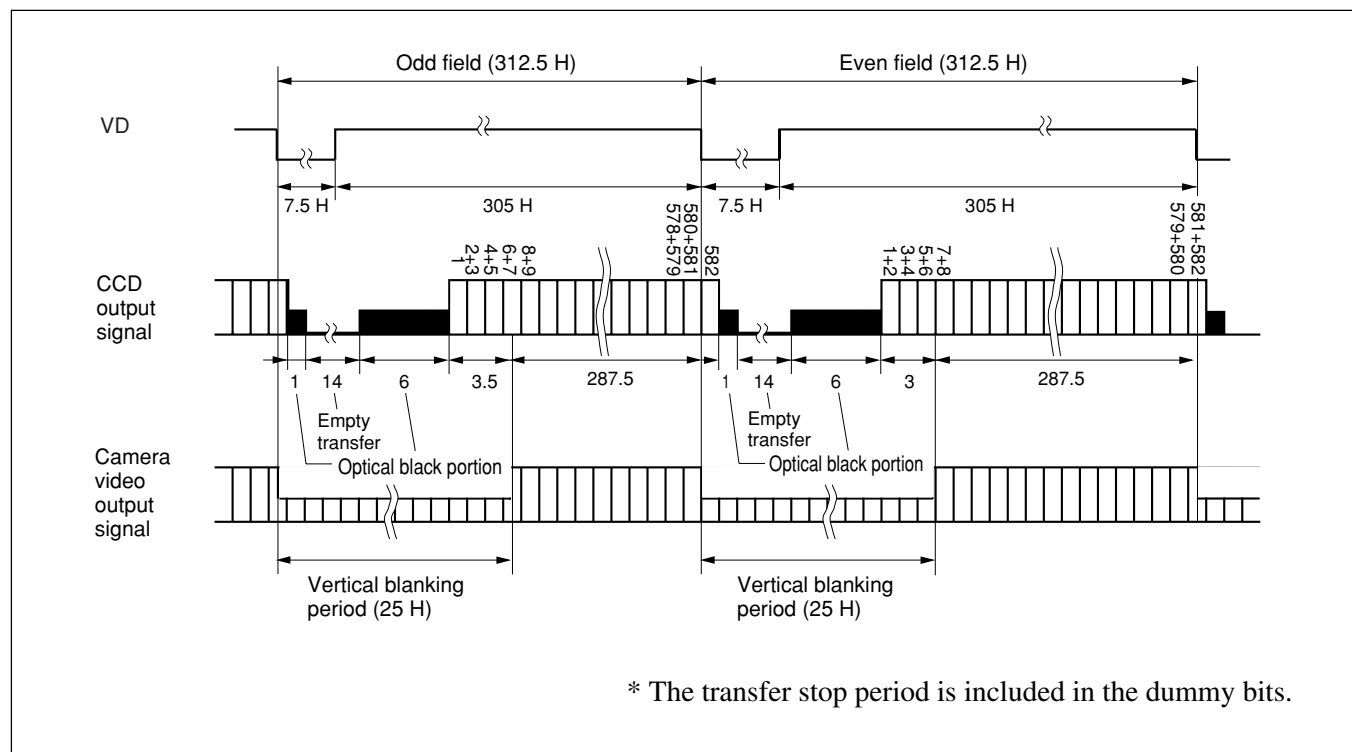

Sony reserves the right to change specifications of the products and discontinue products without notice.  
Technical information contained herein is for reference only and does not convey any license by any implication or otherwise under any intellectual property right or other right of Sony or third parties.  
Sony cannot assume responsibility for any right infringements arising out of the use of this information.